

USER'S MANUAL

WB240 and WB230

*Computer
Wheel Balancers*

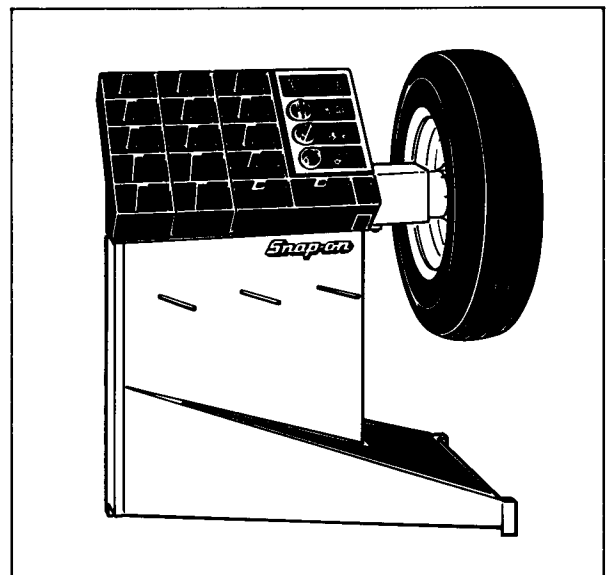

Snap-on®

Operator Tips

1. Read this instruction manual completely before balancing wheels with your new balancer.
2. **Wear approved eye protection when removing weights and using a hammer to attach them.**
3. The standard voltage converter supplied with the balancer operates off a 115 VAC, 50/60 HZ power source and converts line voltage to 8.5 VAC. Other converters are available.
4. The balancer will automatically return to the "normal" balancing mode if the power supply is interrupted.
5. The balancer has no power switch, but can be left plugged in at all times, as it consumes only 5 watts of power.
6. Be sure balancer is sitting on all three feet without weights, rocks, etc. jammed under the base.
7. Remove all stones, old weights, and other foreign material from the wheel before balancing.
8. The wheel must be centered and tightened down snugly onto the shaft of the balancer before spinning.
9. Check that all wheel weights are properly applied and secured.

Standard Accessories

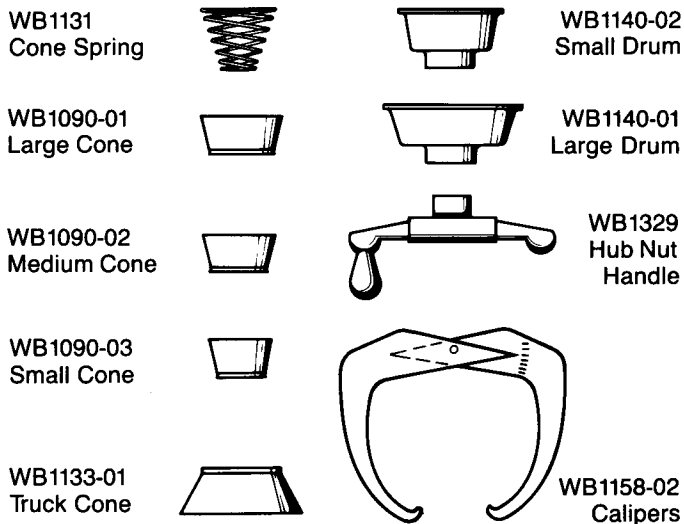

WBA1-A Extension Adaptor

The extension adaptor is used for some duplex light truck wheels, after-market reverse offset wheels, and any application where the wheel must be moved away from the machine.

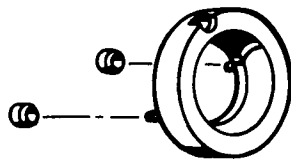

WBA2 Universal Wheel Adaptor

Universal wheel adaptor fits 3, 4, 5, 6, 8, 10 hole patterns.

This adaptor is used on wheels with untrue center holes, and wheels with closed centers. (See WBA2 instructions on pg. 8).

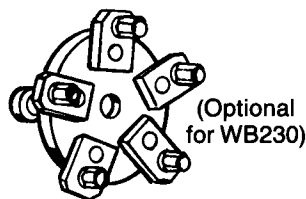

Optional Accessories

- Metric Bolt Plate Adaptor WB1499
- Extra Small Cone WB1090-04
- Motorcycle Adaptor WBM1419

Specifications

- Dynamic and Static, Twin Plane Balance
- Four modes: Normal, Static, Fine and Alu/mag.
- Single spin cycle (7 seconds max)
- Weight displayed in .25 ounce (5 grams) increments
- Accuracy to .1 ounce (2 grams)
- Ounce-gram conversion by activating switch
- Tire width 3 1/2–19" (89–483 mm)
- Rim diameter 10–20" (254–508 mm)
- Maximum tire diameter 44" (1117 mm)
- Maximum tire weight 154 lbs (70 kg)
- Automatic Calibration
- Operation from 110/120/220/240 volts, 50/60 Hz or external 12 volt battery.

Installation

A. Check list of contents.

Qty Item

- 1 Measuring head, including four hex screws (5/16-18 UNC x 3/4") and washers
- 1 Weight Tray and mounting hardware (for WB240)
- 1 Base
- 1 Stub shaft
- 1 Bolt 3/8"-24 UNF x 6"
- 1 Power converter
- 1 Owner's manual

Plus equipment accessories shown on Page 2.

B. To assemble measuring head to base, place base on firm floor. Loosen four hex screws in bottom of measuring head (it is not necessary to remove them).

Align hex screws with slots and key holes in base, set in place and slide to rear. Make sure that washers rest between hex heads and metal plate of base. Tighten all four screws. Recommended torque 100-120 in.-lbs.

C. Verify correct power outlet voltage, as shown on converter housing.

Connect cord from voltage converter to connector on back of measuring head.

D. Plug converter into wall outlet or run extension cord to converter in converter holder.

A buzzing sound may be heard briefly and position lights will come on.

E. Install stub shaft as shown. Torque bolt to 250-300 in.-lbs.

The balancer is now ready for use.

Ounce/Gram Switch

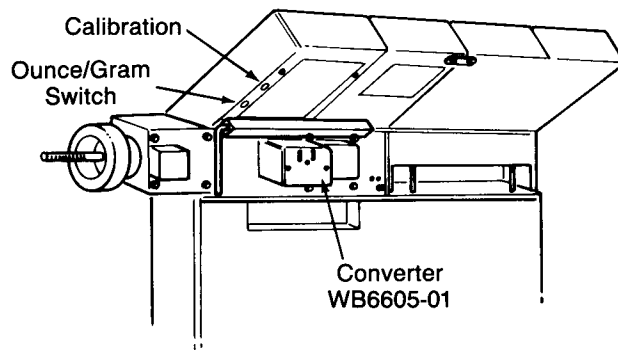

The balancer will read in either ounces or grams. Set the Ounce/Gram Switch, (recessed in hole on back panel marked Oz/Gm) as desired. (See drawing.) Pressing the switch changes the readout. It will read in ounces with the decimal lit and in grams when the decimal point is not lit.

NOTE: The wheel must be respun to obtain the correct reading after the switch has been changed.

12 Volt Battery Operation

The balancer may be powered by any 12V battery. Connection is made to the same input connector as the normal power converter. Either polarity may be used.

12 Volt Cable Connectors

The user can make up his own 12 volt cable connector as shown.

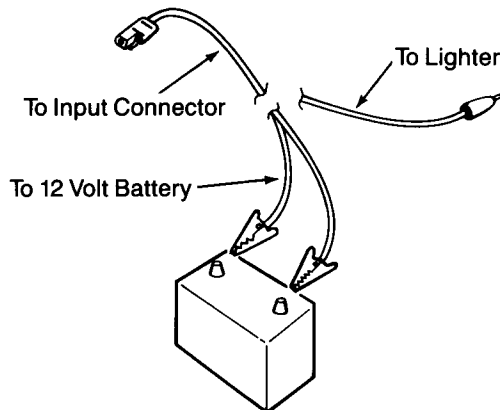

Operation

1. Mount Wheel

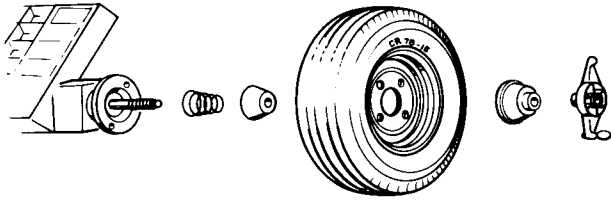

See page 6 for alternate mounting methods.

- A. Choose cone that fits best when placed through wheel center hole from rear. Slide the cone spring and cone on the shaft as shown. The cone must center the wheel.
- B. Choose a pressure drum that contacts wheel on a flat surface to avoid centering wheel with pressure drum.
- C. Tighten wheel firmly against face plate — hold hub nut handle in place and rotate the wheel when tightening. Wheel must be firm against face plate and threads must engage a minimum of three turns.

With few exceptions, all known original equipment wheels and most after market wheels can be mounted using some combination of the standard adaptors.

2. Select Balance Mode

Normal Balancing

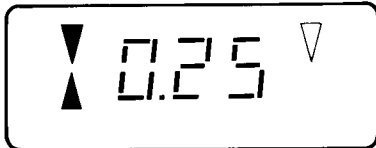

Most balancing is done in the "Normal" dynamic setting. The balancer is set for "Normal" balancing when the "Alu" "S" and "F" indicators are not lit.

To select special balance mode, rotate the rim diameter knob counterclockwise past the 3 and clockwise back to the rim size setting.

Alu/Mag Balancing

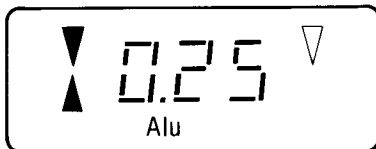

Aluminum/Mag Wheel Balancing (Hidden weight).

Static Balancing

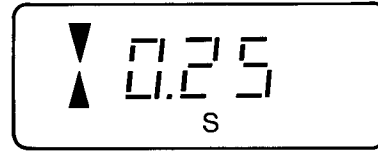

Static, single plane balance.

Fine Balancing

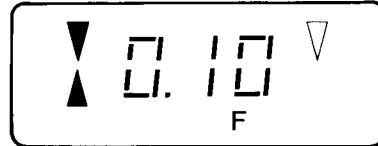

Dynamic Balancing to 0.10 oz (2 gr) accuracy

For Alu, Static, and Fine Balancing, see Special Mode section (page 7).

3. Set Rim Diameter

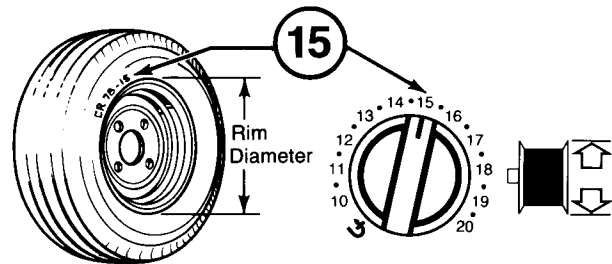

Set diameter knob to diameter shown on tire sidewall.

4. Set Rim Width

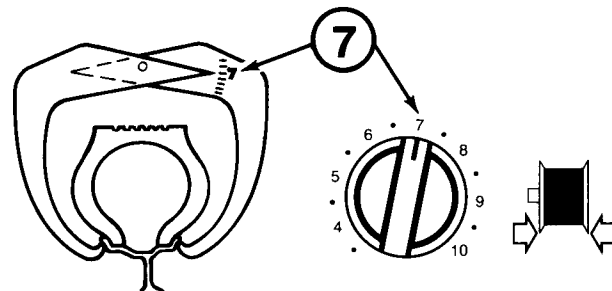

Measure wheel with caliper. Set width knob to width measured.

5. Set Rim Distance

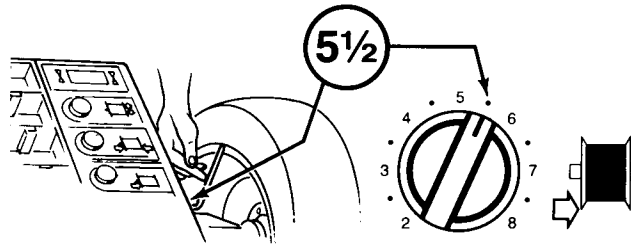

- Pull rim distance gauge arm out and position the tip against the rim bead surface or where the inner weight is to be placed.
- Read the rim distance value off the gauge arm at the point where it enters into the housing.
- Set the rim distance knob to the rim distance value.

6. Turn Handle...Release

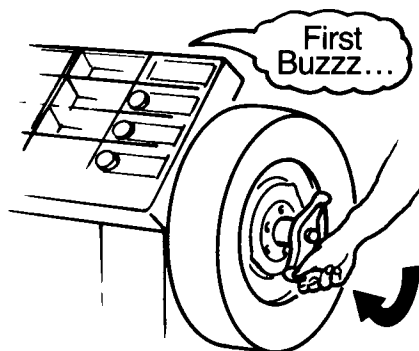

Turn crank handle clockwise until buzzing sound is heard and the display blanks. Release handle immediately. Allow wheel to spin freely until measuring cycle is completed and wheel stops.

Normal balance speed is approximately 90 rpm; if spun to fast, buzzer will sound continuously until wheel slows to measuring speed. Balancer will function normally even though wheel is spun too fast, but balance cycle time will increase.

If wheel is turned in the wrong direction (counter clockwise) buzzer will sound and "EEE" will appear in display window. The brake will not function if the wheel is spun the wrong direction. Turning wheel in proper direction will remove "EEE"s and allow balancer to function properly.

NOTE: Do not lean on machine during measuring cycle; otherwise wrong readings may result.

7. Attach Weight

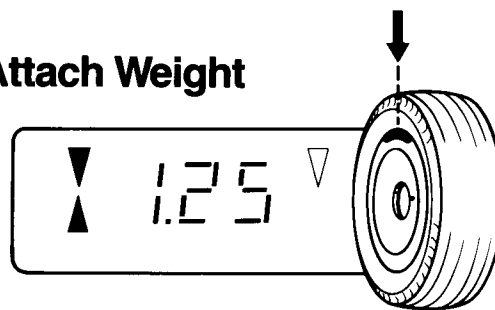

Starting with either inner or outer side of wheel rotate wheel in direction of lit arrow until both arrows light indicating correct position, the correct weight will be displayed. Securely apply indicated weight at top dead center (inner shown). Repeat for other side.

8. Check Spin

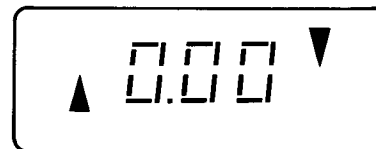

Repeat spin cycle. Zero weight readings should be displayed. Occasionally it will be necessary to add small additional weights.

Mounting Tips

General

Careful mounting is very important since the wheel is balanced according to how it is mounted on the balancer. If the wheel is not well centered it will be misbalanced. The majority of stud centered automobile wheels have concentric center holes allowing rapid cone mounting. The use of the various adapters should be restricted to problem situations and after market specialty wheels.

Mounting Errors

Regardless of mounting method employed, it is very important to determine that the wheel is centered before any balancing operations are undertaken. Wheels are to be mounted on the appropriate cone, or adapter and carefully tightened to assure proper centering and mating against the back flange. It is extremely important that the wheel, and in particular, the portion which mates

(continued on next page)

5. Set Rim Distance

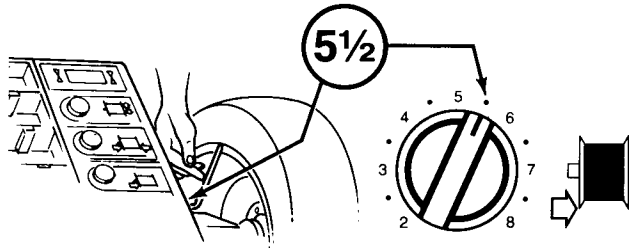

- Pull rim distance gauge arm out and position the tip against the rim bead surface or where the inner weight is to be placed.
- Read the rim distance value off the gauge arm at the point where it enters into the housing.
- Set the rim distance knob to the rim distance value.

6. Turn Handle...Release

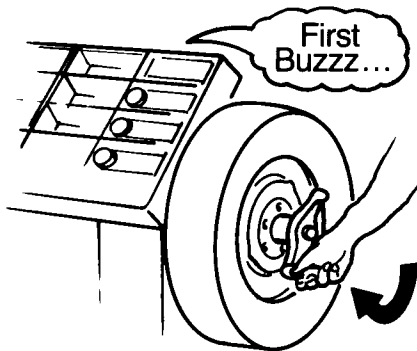

Turn crank handle clockwise until buzzing sound is heard and the display blanks. Release handle immediately. Allow wheel to spin freely until measuring cycle is completed and wheel stops.

Normal balance speed is approximately 90 rpm; if spun to fast, buzzer will sound continuously until wheel slows to measuring speed. Balancer will function normally even though wheel is spun too fast, but balance cycle time will increase.

If wheel is turned in the wrong direction (counter clockwise) buzzer will sound and "EEE" will appear in display window. The brake will not function if the wheel is spun the wrong direction. Turning wheel in proper direction will remove "EEE"s and allow balancer to function properly.

NOTE: Do not lean on machine during measuring cycle; otherwise wrong readings may result.

7. Attach Weight

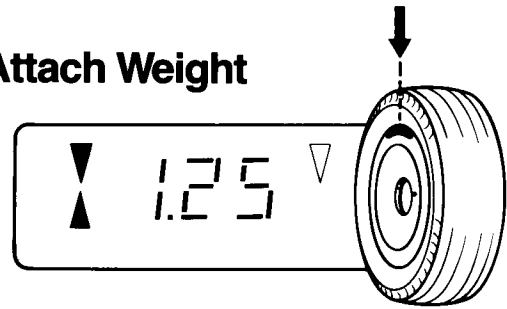

Starting with either inner or outer side of wheel rotate wheel in direction of lit arrow until both arrows light indicating correct position, the correct weight will be displayed. Securely apply indicated weight at top dead center (inner shown). Repeat for other side.

8. Check Spin

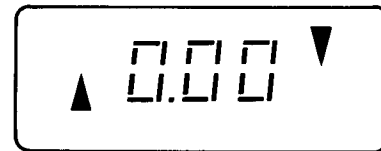

Repeat spin cycle. Zero weight readings should be displayed. Occasionally it will be necessary to add small additional weights.

Mounting Tips

General

Careful mounting is very important since the wheel is balanced according to how it is mounted on the balancer. If the wheel is not well centered it will be misbalanced. The majority of stud centered automobile wheels have concentric center holes allowing rapid cone mounting. The use of the various adapters should be restricted to problem situations and after market specialty wheels.

Mounting Errors

Regardless of mounting method employed, it is very important to determine that the wheel is centered before any balancing operations are undertaken. Wheels are to be mounted on the appropriate cone, or adapter and carefully tightened to assure proper centering and mating against the back flange. It is extremely important that the wheel, and in particular, the portion which mates

(continued on next page)

Special Modes

Aluminum Alloy/Mag Wheel Mode (Hidden weight — 4" apart)

For balancing alloy wheels using hidden weights, rotate rim diameter knob counter-clockwise past 10 to  and return to correct diameter setting. "Alu" will light to indicate that machine will now operate in the Alu mode.

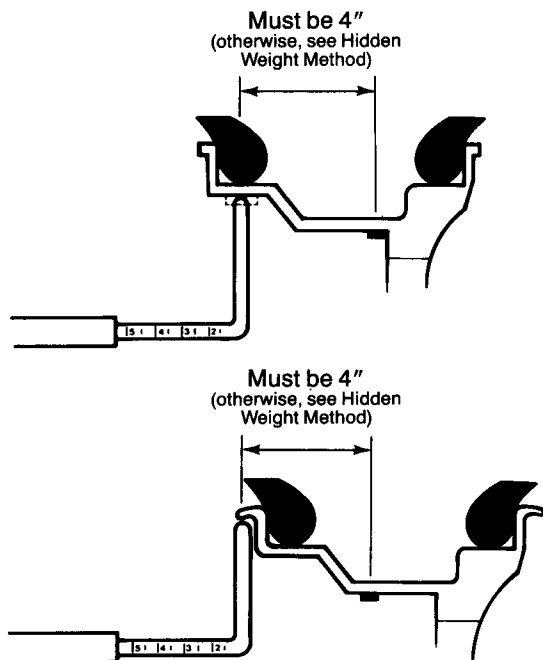

Set Rim Diameter for the wheel diameter shown on wheel. Rim width setting may be omitted, but weights must be attached 4" apart. Set rim distance for actual location of inner weight as measured with the Rim Distance Gauge.

Static Balance Mode

For static single-plane balance, rotate rim diameter knob counterclockwise past 10 again to  and return to correct diameter setting. "S" will light to indicate that machine will now operate in static mode.

Rim width and Rim distance need not be set in static mode.

Only the inner display of position and weight will show. The static weight may be placed on the inner, outer or center of rim.

Static balancing is useful when weights can only be placed in one location, i.e. specialty mag wheels or motorcycle wheels.

Fine Balancing Mode

For fine balancing, rotate rim diameter knob counter-clockwise past 10 again to  and return to correct diameter setting. "F" will light to indicate that machine will now operate in the fine balancing mode.

This mode allows balancing to an even higher degree of accuracy than is possible with the smallest commercially available weights. Accuracy is improved to 0.1 oz. (2 gm). This degree of very fine balancing is seldom necessary. It is useful to balance racing tires, tires of cars with extremely sensitive suspension systems and for machine calibration.

NOTE: When fine balancing, it is usually necessary to trim the smallest standard weight in order to obtain the weight needed for a zero check spin.

Hidden Weight Method

This method is an alternative to the "Alu" mode. Using either the normal mode or "F" (Fine) mode.

Set Rim Diameter

When using stick-on weights, set knob $1\frac{1}{2}$ less than diameter noted on tire sidewall. The "thicker" the rim, the lower the rim diameter setting must be.

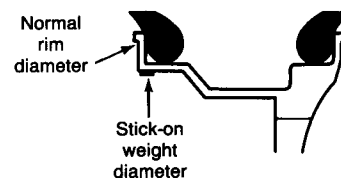

Set Rim Width

For hidden weights, measure between A and B in inches and set this width. Attach weight at points A & B.

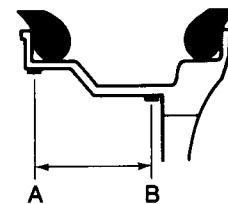

Set Rim Distance

For Clip-On weights:

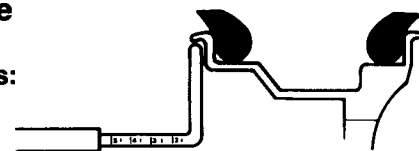

For Stick-On weights:

For "Stick-on" weights, pull gage arm out to center of area where the inner weight is to be placed. Set rim distance to value measured.

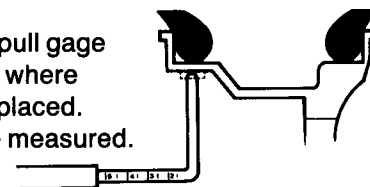

NOTE: Always make sure that the stick-on weights will clear the vehicles disc brake calipers.

Universal Wheel Adaptor

Instructions:

STEP 1: Install swivel plates for selected lug pattern

Select lug pattern, i.e.; three, four or five lugs. (For six lugs select three, for eight lugs select four, etc.) Follow stamped numbers on back of adaptor plate to match selected lug pattern.

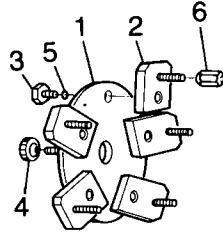

Install swivel plates, **Item 2** to adaptor plate, **Item 1**. Insert swivel screw, **Item 3** (with O-ring, **Item 5**) and tighten snug, then back off just enough so that swivel plate can be rotated.

STEP 2: Install adaptor on back of wheel

Move all swivel plates into same direction and to approximately the diameter of the hole pattern of the wheel. Insert into mounting holes of wheel from back of wheel.

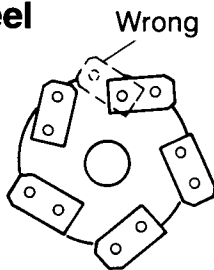

NOTE: This is done best with wheel at a 45° angle leaning against balancer or bench. Insert lower swivel studs first, then align and tilt top studs into place.

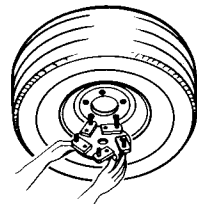

STEP 3: Install and uniformly tighten wheel nuts

Tilt wheel into vertical position while holding wheel and adaptor together, and install wheel nuts, **Item 6**. For best results, set all wheel nuts hand tight, then torque gradually to 75 in-lbs using an alternating sequence several times around the wheel.

DO NOT USE IMPACT TOOLS.

The WBA2-6A Wheel Nut has a 90° tapered end and a 60° tapered end. Use the 90° tapered end on most wheels. Use the 60° tapered end on wheels with 60° countersunk stud holes, such as Honda wheels. A 14 mm spherical nut WBA2-6 is available as an option for old style VW wheels.

STEP 4: Tighten swivel screws on back of adaptor.

Torque swivel screws to 75 in-lbs.

STEP 5: Mount wheel and adaptor assembly on balancer

Check cleanliness of rear surface of the adaptor and flange surface of balancer prior to mounting, otherwise adaptor might not sit firmly, resulting in erroneous readings. Mount wheel and adaptor to balancer.

Install and tighten the two flange nuts, **Item 4** and tighten firmly on back of balancer flange. It is absolutely essential that the flange nuts are completely tight, otherwise erroneous readings may occur. If in doubt, double check tightness of flange nuts after first spin.

STEP 6: Proceed with balancing

NOTE: Any subsequent wheel of identical size can be mounted directly to the adaptor without removing it from the balancer and readjusting the swivel plates. However, when mounting wheel to adaptor, hand tighten wheel nuts and then torque gradually to 75 in-lbs using an alternating sequence while rotating the wheel several times.

Item	Part #	Description	Qty
1	WBA2-1	Adaptor Plate Assembly	1
2	WBA2-2	Swivel Plate Assembly	5
3	WBA2-3	Swivel Screw	5
4	WBA2-4	Flange Nut	2
5	WBA2-5	O-Ring	5
6	WBA2-6	Wheel Nut (14mm) (optional)	5
6	WBA2-6A	Wheel Nut (60°) (standard)	5

Operational Check

1. Plug in balancer. Buzzing sound may be heard briefly and position lights will come on.
 2. Rotate rim diameter knob to  and back to 14" four times. Special mode indicators "Alu" "S" and "F" should light in sequence, ending in the normal mode (where no special mode indicators light).
 3. To check calibration "Fine" balance a typical wheel to zero. Attach a 3 ounce weight to the outer light spot (12 o'clock with both arrows lit). Then spin the wheel and note readings. Repeat with the 3 ounce weight on the inner light spot. The balancer is within calibration limits if the reading is 2.75 to 3.25 for side with 3 oz. weight and the reading is 0.00 to 0.25 on side without the weight. If readings are within these limits, proceed to step 4. Otherwise verify knobs are set correctly for the wheel and proceed with FIELD CALIBRATION, before proceeding to step 4.
 4. Remove calibration weight and verify wheel is fine balanced. Rotate the zero balanced wheel 180° in relation to the mounting flange and re-spin. The total between the inner and the outer readings should be 0.50 oz. (015 gm) or less for a 14" or smaller wheel. If total is higher, repeat this step, making sure the wheel is properly centered when tightening the hub nut. Clean mounting surface, spindle, cones and wheel. If still too high, repeat with a new wheel.
 5. At the end of each measuring cycle the brake should stop the wheel smoothly (in 1/2 to 2 revolutions for a normal 14" wheel).
 6. If the balancer fails any of the above steps, contact your sales representative for assistance in correcting the problem.
- NOTE:** If readings appear to be inconsistent or additional weights are continually called for, verify that wheel is not slipping on the flange when brake is applied.

Automatic Field Calibration Procedure

The balancer is calibrated at the factory before shipment and should not normally require recalibration. See operational check procedure to determine if field calibration is necessary. Calibration is automatic in that the balancer computer is self-adjusting. If calibration becomes necessary, perform the following steps:

- | | |
|---|---|
| 1. Fine Balance Wheel
Display shows zeros | Mount any wheel on balancer.
NOTE: It is advisable to use a wheel similar to those most commonly balanced.
With balancer in "Fine" mode, balance the wheel to zero with control panel knobs set to the appropriate values for the wheel being used.
NOTE: Accurate settings of knobs is required, or miscalibration will result. |
| 2. Attach Required Weight
Ounce mode 3 oz.
Gram mode 100 gm | Rotate wheel until both outer position arrows illuminate. Attach the required weight (see table at left) to wheel on outer rim at top dead center.
NOTE: Calibration will only be as good as the accuracy of this weight. |
| 3. Press "CAL" Button
Display shows flashing "ccc" | With 3 zeros showing in the display window, depress CAL button in recessed hole on back of panel (see drawing on page 3). The display will show a flashing "ccc". |
| 4. Spin Wheel
Each time flashing "ccc" appears (minimum of 4 spin cycles) | While "ccc" display is flashing spin wheel. The buzzer will sound and the balancer will go through a measuring cycle. Repeat the spin cycle each time the flashing "ccc" appears. In the event the wrong weight is attached, control knobs are set incorrectly or accidentally changed, the calibration process is aborted and "EEE" is displayed. In such case, verify all values are correct and repeat the entire procedure. A malfunction exists if "EEE" continues to appear, however, the balancer will still operate with the original calibration values.
NOTE: When "EEE" is displayed, balancer returns to normal mode. |
| 5. Calibration Complete
Calibration weight displayed on outer, zeros displayed on inner | When calibration weight value appears continuously, the balancer is fully calibrated and ready for use.
NOTE: If calibration procedure is abandoned before completion, original values are retained. |

WB240/230 Parts List

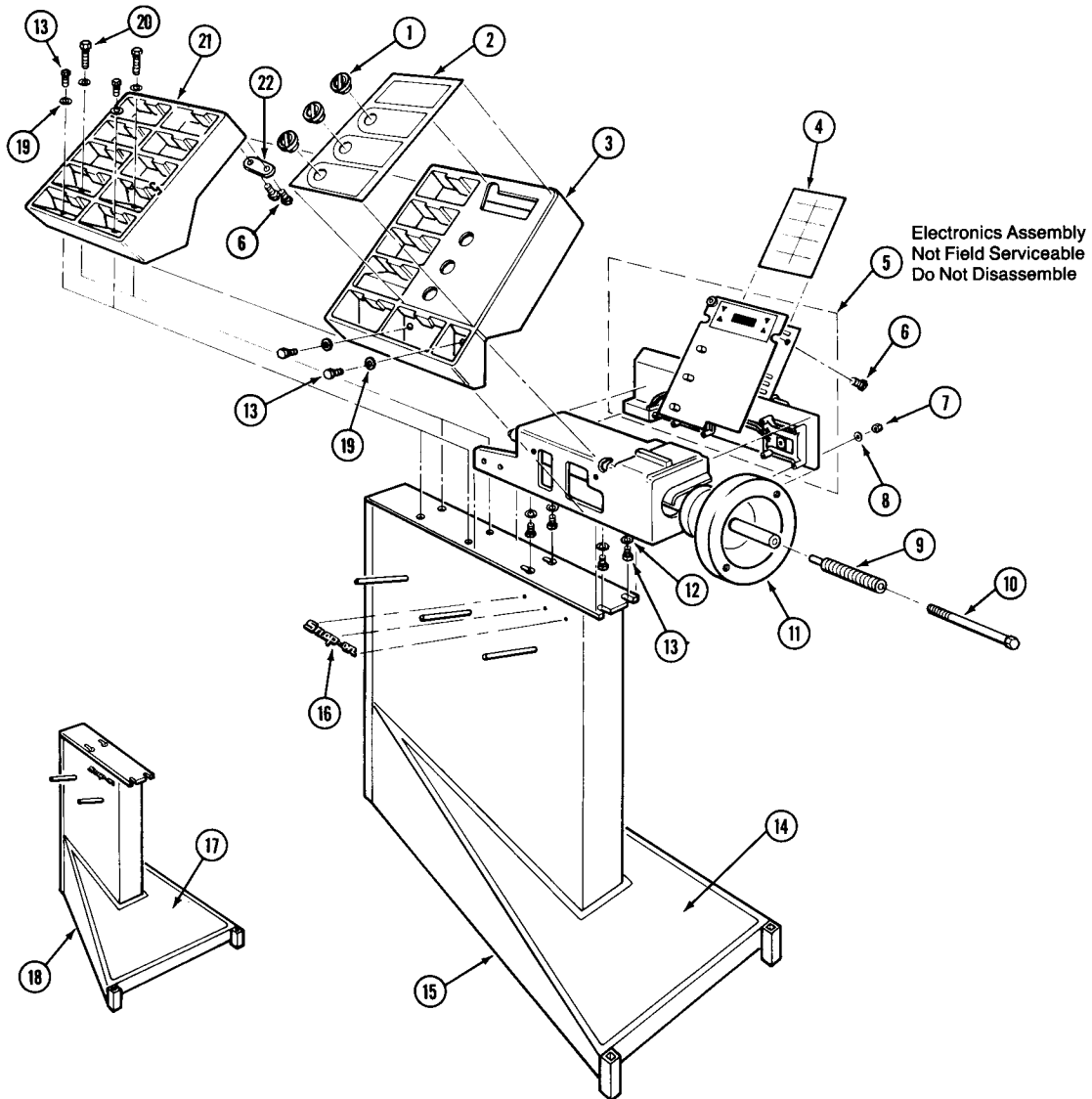

Key	Part #	Description	Qty.	Key	Part #	Description	Qty.
1	WB1591	Control Knob	3	13	WB0102-3118-12	Hex Bolt, 5/16"-18 x 3/4"	8 (6 on WB230)
2	WB1538-01	Front Panel	1	14	WB1579-02	WB240 Base Mat	1 (WB240 only)
3	WB1531	Control Housing	1	15	WB1543	WB240 Base	1 (WB240 only)
4	WB1643	Instruction Card	1	16	KN300R	Logo Package	1
5	WB1601	Electronics Assembly	1	17	WB1579-01	WB230 Base Mat	1 (WB230 only)
6	WB0101-1032-08	Screw, 10-32 x 1/2"	4 (2 on WB230)	18	WB1547	WB230 Base	1 (WB230 only)
7	WB0302-1032	Hex Nut, ESNA 10-32	9	19	WB0205-0031	Flat Washer, 5/16	6 (2 on WB230)
8	WB0201-0010	Flat Washer, #10	9	20	WB0102-3118-48	Hex Bolt, 5/16"-18 x 3"	2 (WB240 only)
9	WB1179-02	Stub Shaft	1	21	WB1532	Weight Tray	1 (WB240 only)
10	ME3A72	Hex Bolt, 3/8"-24 x 6"	1	22	WB1569	Bracket	1 (WB240 only)
11	WB1592	Housing Assembly	1	Not	WB1595-01	Weight Label Set — Ounces	1
12	WB0205-0032	Washer, 5/16"	4	Shown	WB1595-02	Weight Label Set — Grams	Optional

Cover Assembly

To Remove Cover Assembly:

1. Disconnect voltage converter.
2. Remove control knobs from front panel. Pull straight off.
3. Remove two 1/2" Hex size bolts and washers from bottom weight tray pockets.
4. Remove three screws (two on WB230) from upper portion of back panel.
5. Lift cover off head assembly.
6. Reassemble by reversing steps 1 thru 5. Make sure cover is positioned properly in notches of P.C. Board before installing screws and bolts.

Electronics Assembly

To Remove Electronics Assembly:

1. Remove cover assembly.
2. Remove nine 3/8" hex size nuts and washers on lower portion of back panel.
3. Slide electronics assembly off mounting studs.
4. Prior to reassembly, verify anvil assembly is positioned 1/8" in front of raised mark on aluminum housing. Also be sure there is a .03" to .06" gap between the bottom of the anvil assembly and the aluminum housing.
5. Reassemble by reversing steps 1 thru 3. When sliding electronics assembly into place on mounting studs:
 - a) Push the solenoid plunger into its housing.
 - b) Gently push forward on anvil to provide clearance for solenoid to slide into place.
 - c) Verify that the timing disc is centered in opto housing.

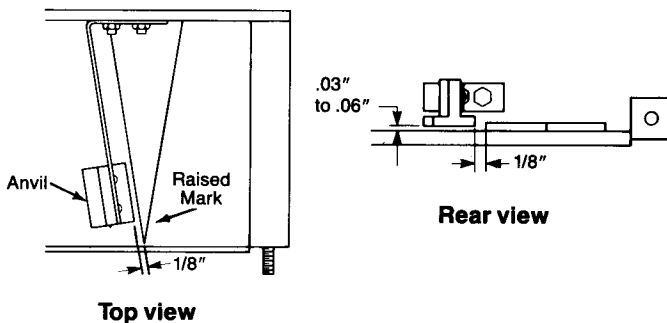

Brake Assembly

Although not normally necessary, removal and replacement of the timing disc and brake mechanism is accomplished as follows:

1. Remove cover assembly.
2. Remove electronics assembly.
3. Remove anvil assembly (2 screws with ESNA nuts and washers).
4. Remove pressure plate:
 - a) Remove 9/16" hex size shoulder screw assembly.
 - b) Slide pressure plate off spindle.
5. Remove timing assembly and key.
6. To reassemble, reverse steps 1 thru 5. When assembling:
 - a) Grease I.D. of pressure plate.
 - b) Tighten shoulder screw until it bottoms out (150 in-lbs). Bellville springs must be compressed.

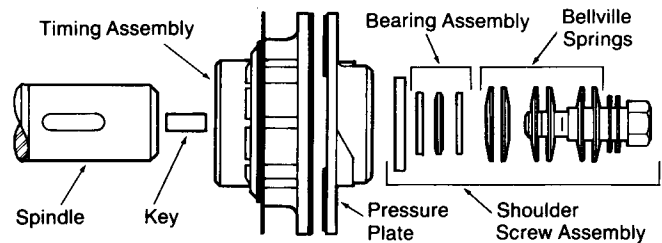

Service & Repairs

The balancer is completely field serviceable. The balancer can also be serviced at your authorized *Snap-on* Service Center. If the balancer appears to malfunction (i.e., brake does not work, cycle time is too long, Alu mode does not light, etc.), reset computer by disconnecting and reconnecting the power. Replacement parts and service assistance are available from your sales representative.

Maintenance

1. Clean mounting adaptors, mounting surface, and spindle of balancer regularly. Grease and oil accumulated dirt, cause out-of-balance and act as a grinding compound resulting in premature wear.
2. Remove wheel weights and trash from under balancer and remove tires, tools or parts that may be leaning against balancer. Make sure the balancer rests only on the 3 foot pads.
3. Clean control panel with window cleaner.



Snap-on[®]

© SNAP-ON TOOLS CORPORATION, KENOSHA, WI 53141-1410

FORM ZWB240/WB230
PRINTED IN U.S.A. Rev. 2/86
"FOR REFERENCE ONLY"

Specifications subject to change without notice. Patents Pending.

