



Notice

The information contained in this guide is subject to change without notice.

This document contains proprietary information which is protected by copyright. All rights are reserved. No part of this document may be photocopied, reproduced or translated without the prior written consent of the John Bean Company.

Print History

First Print	December 1994	FORM 5172
Second Print	November 1995	FORM 5172-1
Third Print	August 1996	FORM 5172-2
Fourth Print	December 1996	FORM 5172-3
Fifth Print	September 1997	FORM 5172-4

IMPORTANT SAFETY INSTRUCTIONS

When using this equipment, basic safety precautions should always be followed, including the following:

1. Read all instructions.
2. Do not operate equipment with a damaged power cord or if the equipment has been damaged - until it has been examined by a qualified authorized service technician.
3. If an extension cord is used, a cord with a current rating equal to or more than that of the machine should be used. Cords rated for less current than the equipment may overheat. Care should be taken to arrange the cord so that it will not be tripped over or pulled.
4. Always unplug equipment from electrical outlet when not in use. Never use the cord to pull the plug from the outlet. Grasp plug and pull to disconnect.
5. To reduce the risk of fire, do not operate equipment in the vicinity of open containers of flammable liquids (gasoline).
6. Keep hair, loose fitting clothing, fingers and all parts of the body away from moving parts.
7. Adequate ventilation should be provided when working on operating internal combustion engines.
8. To reduce the risk of electric shock, do not use on wet surfaces or expose to rain.
9. Do not hammer on or hit any part of the control panel with weight pliers.
10. Do not disable the hood safety interlock system or bypass the intended operation.
11. Do not allow unauthorized personnel to operate the equipment.
12. Use only as described in this manual. Use only manufacturer's recommended attachments.
13. Always securely tighten the wing nut before spinning the shaft.
14. ALWAYS WEAR SAFETY GLASSES. Everyday eyeglasses only have impact resistant lenses, they are NOT safety glasses.
15. Balancer is for indoor use only.

SAVE THESE INSTRUCTIONS



309 Exchange Avenue
Conway, AR 72032 U.S.A.

Phone: 501-450-1500
Toll Free: 800-362-8326
Fax: 501-450-1585

Table of Contents

General Specifications and Features	6
Installation Instructions	7
Receiving	7
Unpacking	7
Assembly	7
Space Requirements	7
Power Requirements	7
Control Panel Description	8
Standard Operation Procedures	9
Balancing Checklist	9
Mounting a Tire and Wheel	9
Parameter Entry - Manual	10
Parameter Entry - Semi-Auto (7.6)	11
Placing Weights	12
Specialty Wheel Mounting	13
Front Cone Mounting	13
Light Truck	13
Patch Balancing	13
Optional Lug Adapters	14
Balancing Alloy Wheels	15
ALU-S Mode	15
Match Balance	16-17
Multi-Operator Modes	18
Stored Parameters	18
Inch/MM, Ounce/Gram, Lt. Truck	18
Calibration	19-20
Parameter Entry System	19
Shaft Calibration	20
Function Codes	21
Troubleshooting	22

7.5 / 7.6 General Specifications and Features

Imbalance Accuracy: 0.035 oz. / 1 gram
Imbalance Resolution: 0.01 oz. / 0.1gram
Weight Placement Resolution: +/- 0.35° or .7°
Shaft Size: 1 9/16" diameter (40mm)
Shaft Rotation Speed: 370 RPM @60hz
380 RPM @50hz
Average Cycle Time (14" tire): 4 seconds

Motor Rating: 1 HP
Power Requirements: 230 V 60hz / 1 Ph
230 V 60hz / 3 Ph
208 V 60hz / 3 Ph
30 Amp Circuit

Rim Width: 1.5" - 20" (38.1-508mm)
Rim Diameter: 8" - 30" (203.2-762mm)
Max Tire Diameter: 44" (1117.6mm)
Max Tire Width: 19" (483mm)
Max Tire Weight: 150 lbs. (70kg)

Footprint: 55" x 60" / 1408 x 1524mm
Shipping Weight: 540 lbs. (245 kg)
Shipping Volume: 80.0 cu. ft. (2.3 m³)
Wheel Weight Pockets: 21

Standard Equipment

- (1) Rim Width Caliper
- (1) Calibration Weight
- (1) Weight Pliers
- Haweka Shaft Adapter Kit consisting of:
 - (1) Quick Speed Nut
 - (1) Clamping Hood
 - (1) Pressure Ring
 - (1) Centering Cone, 1.6-2.6" dia.(42-65mm)
 - (1) Centering Cone, 2.4-3.1" dia.(61-79mm)
 - (1) Centering Cone, 2.9-3.6" dia.(74-92mm)
 - (1) Centering Cone, 3.4-5.1" dia.(87-131mm)
 - (1) Allen Wrench
 - (1) Basic Centering Device

Options

- Universal Lug Adapter (110614)
- Truck Cone Kit (110612)
 - includes: (1) 4.8 - 6.69" diameter cone
 - (1) Spacer Adapter
- Centerless Wheel Adapter (110570)
- Motorcycle Wheel Adapter (110609)

Major Features

Microprocessor Controlled
Full Stream DSP Technology
Digital Readout: Ounces or Grams
Digital display round-off to .25 oz. (5gr) or .50 oz. (10gr) or non round-off to .05 oz. (1gr)
Wheel Parameter Data Entry

- Manual
- Quick Set Parameter Entry
- Semi-Automatic (7.6 only)
- Inch or MM Rim Diameter Modes

Spin: Hood-activated Autospin or Manual
Single Spin Balancing
10 Balancing Modes, 6 Tape Weight Modes
Match Balancing
Alu-S Mode
Light Truck Mode
2 Plane Top Dead-Center Braking
Smart Calibration

- Patented Dual Plane
- Calibration Reminder
- Programmable Calibration Scheduler (7.6)
- Quick Check Calibration Verification (7.6)

Operator Recall (6)
Wheel Parameter Recall (4)
Multi-Function Spin Counter
Programmable Spin Odometer (7.6 only)
Loose Hub Shutdown
Self-Diagnostic Capabilities
Integrated Weight Anvil
Touch Pad Keyboard
Quick Speed Nut Standard
Fully Enclosed Wheel Guard with safety interlock
Arm's Length Accessory Storage
Adjustable Data Display
Captured Backspring
Heavy Duty Suspension
Synchronous, Cogged Drive Belt

The continuous A-weighted sound pressure level is 71.5 dBA and the maximum instantaneous sound pressure level is 78.6 dBA at the work station.

John Bean Company reserves the right to incorporate changes in designs or materials, affecting product improvements, without obligation of incorporating same on equipment of prior manufacture.

7.5 / 7.6 Balancer Installation Procedures

Location of Balancer

The balancer should be located indoors where convenient to mount and dismount a tire-wheel assembly. Place balancer skid close to the desired position. Allow ample space for wheel mounting and to raise and lower the hood guard. See footprint requirement drawing on the right.

Unpacking the Balancer

Cut banding straps. Use caution to avoid sharp edges of banding. Lift cardboard box upward over balancer top. Cut banding from the hood guard and the accessory package. Set these aside for now. Report any shipping damages or shortages to the carrier at once. Remove the skid mounting bolts from the balancer base. Lift the balancer from the skid and place gently onto the floor. **CAUTION! DO NOT LIFT BALANCER BY THE SHAFT!**

Site Preparation

Make certain the floor area to be used is flat to within one quarter inch beneath the balancer. Make certain this area is free from vibrations created by other heavy equipment, compressors, generators, etc. A concrete floor is strongly recommended. Make certain the three base pads under the balancer are the only places to contact the concrete floor.

Anchoring the Balancer to the Floor

The balancer must be anchored to the floor to provide necessary stability. Failure to secure to floor will invalidate the UL/CUL approval of this balancer.

Mark position of anchor holes by placing balancer in the desired location.

Drill three 1/2" (12.4mm) holes at least three inches deep and place anchor bolts in holes.

Note: Anchors are supplied with balancer, if additional anchors are needed, order part number **61750** each.

Move balancer into position taking care not to lift by shaft. Place over the anchors and tighten shaft side first. Tighten remaining bolts to 60 ft.-lbs. *Do not allow hold down tabs to bend!*

Install Wheel Mounting Adapter:

Locate the shaft adapter and position onto the drive shaft stub which exits the balancer frame to the right. Using the included Allen wrench tighten the hex screw until snug. **NOTE:** Mating surfaces **MUST** be clean and free of factory applied grease.

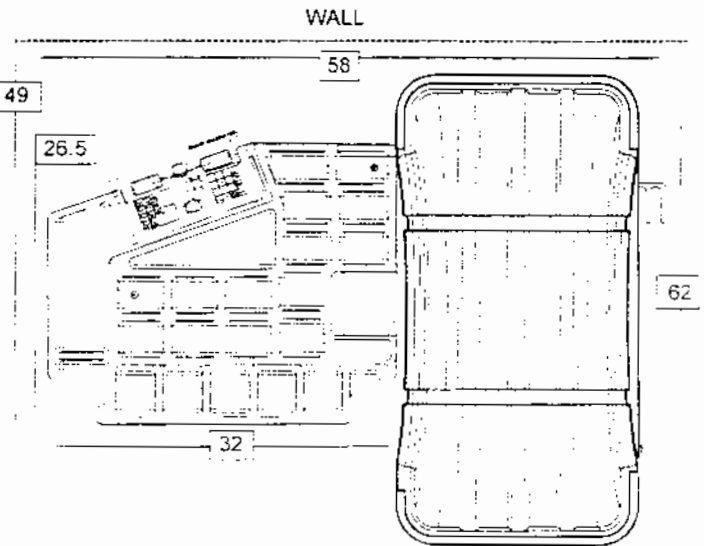

Install Wheel Guard:

Assemble wheel guard to balancer by inserting the guard support frame pivot into support tube in the rear of machine. Place guard pivot cam onto end of pin. Secure cam with two screws. Check guard for proper pivot action.

Installation of Wing Nut hook

Locate the wing nut bracket and associated hardware. Insert the bracket into the rear hole located to the rear and outside of the hood guard frame. Place the formed washer onto the stud. Thread on the lock nut and tighten to 10-12 ft. lbs.

Adjustment of the Display to desired position

The angle of the display console can be adjusted to best suit the operator. To adjust, use a 9/16 wrench to simply loosen the two 3/8" hex bolts located on each side of the rear display mount. Tilt to the desired angle and tighten.

Power Requirements

The balancer operates on 230 volts AC, 50/60 cycle. The current draw is 20 amps, a 30 amp service is recommended.

The power plug used to attach to wall current is supplied at installation for European applications. This plug must be CE approved. It is not permissible to wire directly into the wall circuit.

Replacement motors can be purchased only through an authorized **John Bean** distributor.

Note: The receptacle and balancer **MUST** be properly grounded.

Control Panel Functions

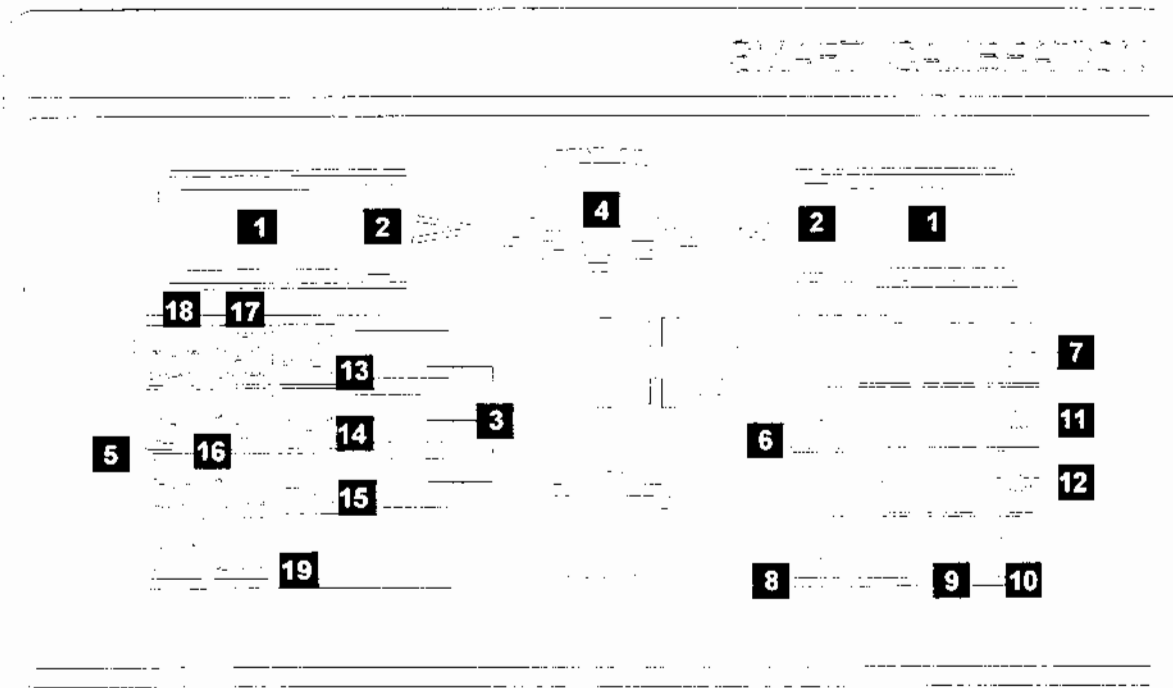

1 Weight Amount and Function Display Window - Shows weight amounts and operation messages.

2 Position Indicator LEDs - Displays the location for wheel weight placement.

3 Parameter Value Display - LED readout of the wheel size and offset values. Values can be input directly using the numeric keypad or by simply rotating the wheel until desired number appears (Quickset).

4 Weight Mode and Placement Display - Displays a pictorial reference of the chosen balance mode.

5 Mode Selection Keypad - The left keypad for entry of mode selection and parameter input.

6 Numeric Entry and Function Keypad - The right keypad used for numeric entry of functions and actual number values for parameters. Including several operator control keys.

7 Multi-Operator Selector - This key toggles between six operators allowing wheel parameters to be undisturbed.

8 Function/Lt. Truck Mode - This key toggles between F code access and balance mode to light truck balance for .5 oz round-off.

9 Cancel - Pressing this key interrupts any process.

10 Enter - This key activates whatever selection has been requested, it also spins the wheel if hood guard is down.

11 Inches and Millimeters - Toggles parameter entry for readout of either inches or millimeters.

12 Ounces and Grams - Pressing this key toggles the machine to readout in ounces or grams.

13 Rim Offset - This key is used to enter the rim offset position using the numbers from the distance gauge.

14 Rim Width - Press this key to enter the rim width. Use the rim width calipers for measurement.

15 Rim Diameter - Enter the rim diameter after pressing this key. Read the size directly from the tire sidewall.

16 Alloy Mode Selection - A series of 5 placement locations for custom weight location. Very useful for the wide variety of custom wheels on today's market.

17 Static Balance Modes - Pressing this key will toggle mode selector display between three static single weight positions.

18 Dynamic Balance Mode - This is the normal operating mode where the vast majority of balance jobs will be done.

19 Match Balance - Use this mode to select Match Balance. Match Balancing places the heavy spot of the tire with the light spot of the rim minimizing the amount of balancing weight required.

Operation of the Balancer

NOTE: Read all instructions before proceeding with operation of the balancer.

WARNING: For operator safety please read and follow the precautions outlined on page 3 of this manual.

All balancer functions are input into the main computer through the large easy to read touch panel. Although each wheel tire assembly differ in some ways all balancing jobs require basically the same procedure. The order of events to take place are:

1. Inspection of the wheel/tire assembly
2. Mounting wheel onto shaft or adapter
3. Entry of wheel parameters
4. Selection of Balancing Mode or placement
5. Spinning the wheel
6. Applying the recommended weight
7. Check spin if desired
8. Dismounting the wheel

The following operation instructions will follow the basic outline above.

Step 1: Check List

Observe Before Balancing Wheel

1. Check for proper air pressure. If not correct, inflate to correct pressure.
2. Check for any foreign material inside tire. If present, remove before balancing tire.

WATER IS FOREIGN MATERIAL!

3. Be sure tire and wheel are free of excessive dirt, rust and large stones. Use wire brush on back side of wheel if necessary.
4. Remove old weights — old weights may be improper value or in wrong location.
5. Be sure that the right size tire has been mounted on the wheel.

Step 2: Wheel Mounting

Standard Wheels (back cone mount)

Nearly all standard wheels and many alloy wheels have accurately machined center holes, and they should be mounted with center cones. Accurate balancing depends on accurate mounting of the wheel and correct seating of the cone in the pilot hole to insure that the wheel is centered on the shaft.

Mount the wheel as detailed below in *Figure 1*:

1. Mount proper cone against spring plate.
2. Mount wheel on shaft in the same manner as you would on the car.
3. Mount pressure ring on speed nut and place against outside of wheel.
4. Tighten speed nut securely with both hands.

NOTE: Some wheels not hub centric may require the use of an optional lug adapter plate.* An adapter plate allows a wheel to be mounted using the lug holes as a center reference.

* Cone, retainer cup, and wing nut may not be needed if adapter plate is used to mount wheel to balancer shaft. See page 14 for lug adapter detail.

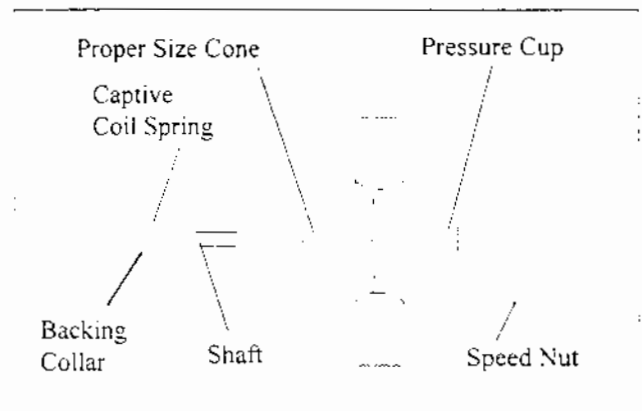

Figure 1 - Standard back cone mounting

Warning

Failure to tighten wing nut securely may result in serious personal injury.



Step 3: Parameter Setup for Standard Wheels (Manual and Quick Set)

Mode Selection

1. Select the desired mode of balance by pressing the proper mode button. The balancer defaults to the "Operator A" when powered up. See Page 18 for details on multi-operator modes. The majority of balancing will take place in 2 plane dynamic, see illustration to the right. The weights will be placed on the rim edge both inside and outside.

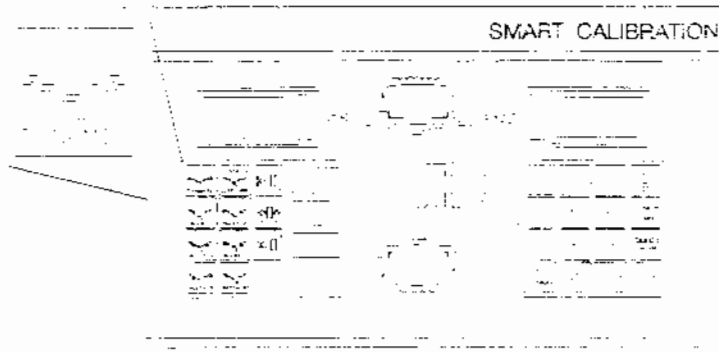

Distance Entry (7.5)

2. Move the distance gauge arm to touch the inner edge of the wheel and observe the reading on the scale of the distance gauge. Press wheel distance button . Enter wheel distance reading by pressing appropriate buttons on keyboard.

Quick Set Method

Rotate the wheel until the desired number appears in the parameter window, after a 2 second pause the number is automatically entered. If entry begins with the distance value, the computer will automatically prompt to the next parameter.

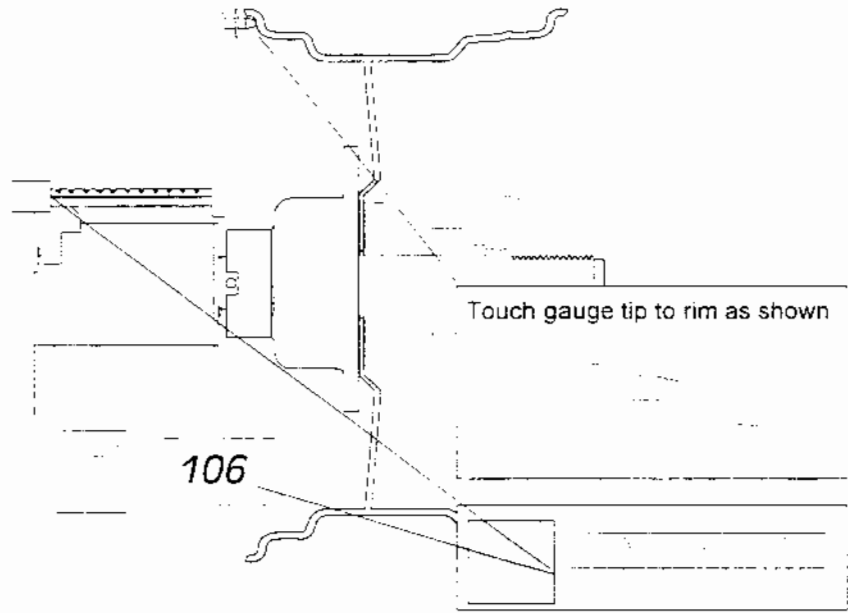

Rim Width Entry

3. Measure rim width using rim width calipers. Measure wheel where corrective weight will be applied. Press wheel width button . Enter the measured diameter directly using the numeric keypad or **Quick Set** method by rotating the wheel assembly until the desired number appears in the parameter window.

NOTE: If clip weights cannot be applied, refer to section "Balancing Alloy Wheels" on Page 17.

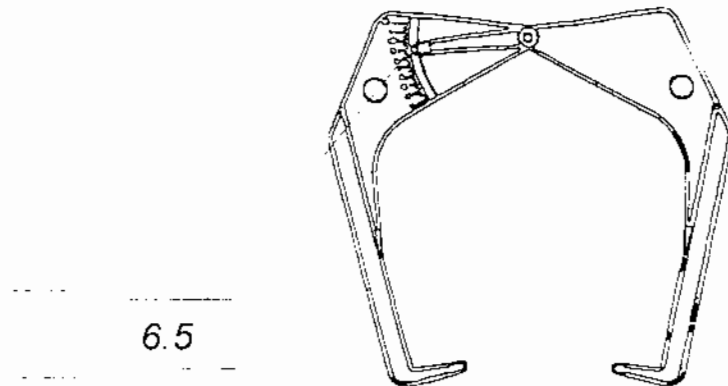

Wheel Diameter Entry (Manual)

4. Press wheel diameter button . Enter wheel diameter (see tire side wall for specification) by pressing the appropriate buttons on the numeric keypad or by the **Quick Set** method, rotating the wheel assembly until desired number

appears in the window. Metric designations may be entered directly after pressing "Inch/MM" function keys (turns on conversion to metric).

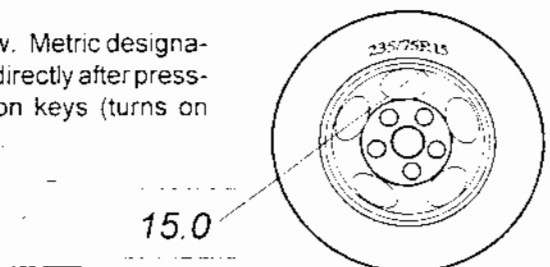

Semi-Automatic Parameter Entry- 7.6

Mode Selection

1. Select the desired weight placement mode of balancing by pressing the appropriate mode button. LED's on the wheel graphic show the weight positions chosen (*Figure 2*). The majority of balancing will take place in the 2 plane dynamic mode. The hammer-on clip weights will be placed on both inside and outside of the rim edge.

Select the operator of choice if wheel parameters are to be saved or if more than one set of wheels is being balanced at the same time. The balancer defaults to "Operator A" when powered up.

Rim Distance and Diameter

2. To activate the electronic *SAPÉ* system move the measurement arm to the edge of the rim, touch the pointer to the rim edge as illustrated in *Figure 3* and hold steady for about a second. The brake will pulse and the selected distance and diameter values will be entered automatically. Release the arm, making sure it returns to its home position on the balancer. Do not allow the measurement arm to "dangle" down in front of the balancer.

Rim Width Entry

3. **Measure rim width** using rim width calipers. Measure wheel where corrective weight will be applied, *Figure 4*. Press wheel width button  and enter the measured diameter directly using the numeric keypad or use the **Quick Set** method by rotating the wheel assembly until the desired number appears in the width parameter window.

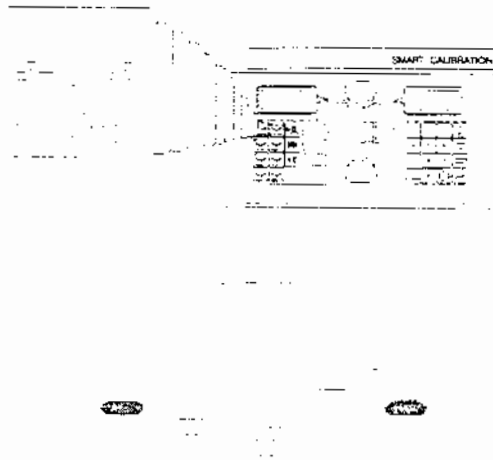

Figure 2 - LEDs indicate weight locations

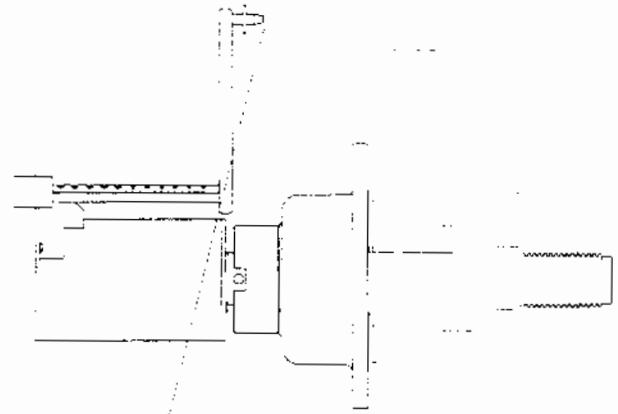

Figure 3

Touch gauge tip to rim as shown

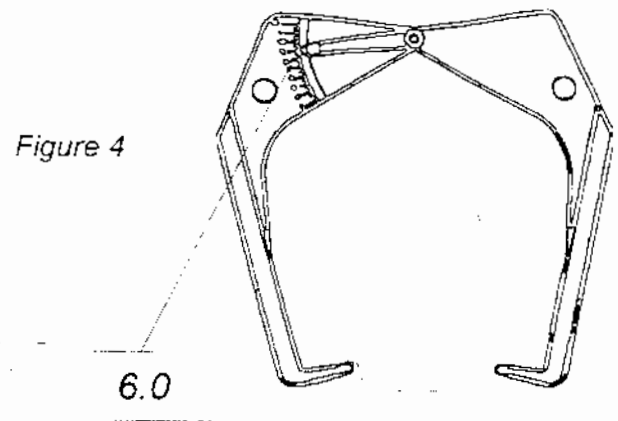

Figure 4

Step 4: Spinning the Wheel

Press "ENTER" or lower the hood to spin. The machine will spin the wheel assembly for several seconds.

NOTE: The 7 Series Balancers feature selectable automatic spin. The shaft spins when the hood guard is lowered or *ENTER* is pressed. Auto-spin can be disabled by pressing the keys "F6" and *ENTER*. Each time *F6* is entered the autospin feature toggles on/off.

Warning!! Do not attempt to bypass or disable the built in hood guard safety features. These guards are for your safety.

The computer calculates for imbalance and location using the current parameters and mode.

The balancer will go into a brake cycle to stop the shaft from turning. When the shaft has come to a stop, the display will read the required weight amount and position to place them.

After spinning, to recalculate the readings for a different placement, balancing mode, or displayed units, simply press the desired button. See *Figure 5*.

Note: If at any time the wheel/tire assembly measures over a total of three (3) ounces imbalance on either plane, a "Match Balance" is recommended. See page 16 for details.

Step 5: Placing Weight

View the weight amount and location windows. See *Figure 6*. Weight values are displayed for the chosen mode location. Lift the hood guard. Rotate the wheel assembly until the position indicator LED turns green. Select the correct type weight and place at the indicated position. Continue to rotate the wheel assembly to the next indicated placement position. Lower the hood guard for a check spin if desired.

WARNING! Be sure to use the proper type clip weights - using the wrong type clip weight may cause serious personal injury or damage to property.

Step 6: Dismounting the Wheel

When the balance is complete, remove the wheel assembly from the balancer. Mount onto vehicle using the manufacturers suggested torque specifications.

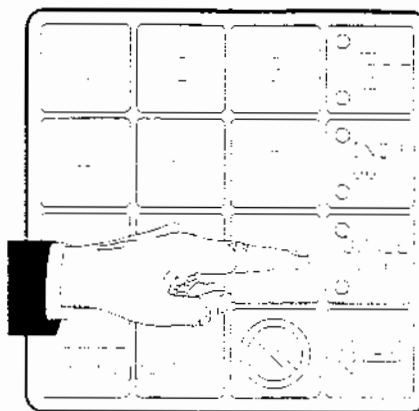

Figure 5 -- To recalculate the weight amounts and locations using a different balancing mode or change to ounces/grams, press the appropriate button. The balancer will display the proper weight amount for that position or mode without respinning.

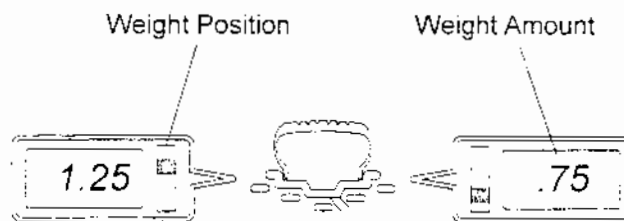
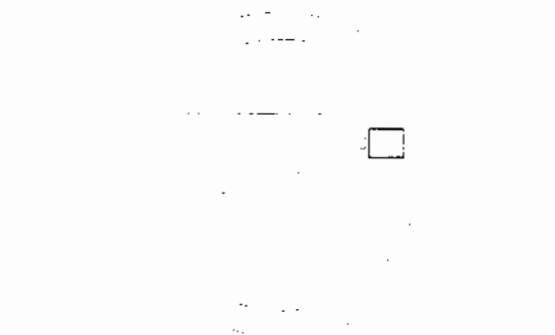

Figure 6 -- LED Display indicates weight amount and position.



Use manufacturers suggested lug torque when remounting wheel onto hub.

WHEEL MOUNTING -- Specialty Wheels

Most special wheels can be accurately mounted and balanced using a centering cone. When using centering cones, be certain cone is properly seated in the wheel's pilot hole.

To balance a wheel with a deep neck, the front cone mounting method may be necessary. Mount the wheel as shown below in *Figure 7*:

1. Mount wheel onto the balancer shaft.
2. Place the proper cone inside the protruding neck of the wheel.
3. Remove the clamping cup from the wing nut. Place the small spacer ring on the nut if needed. Tighten wing nut securely.

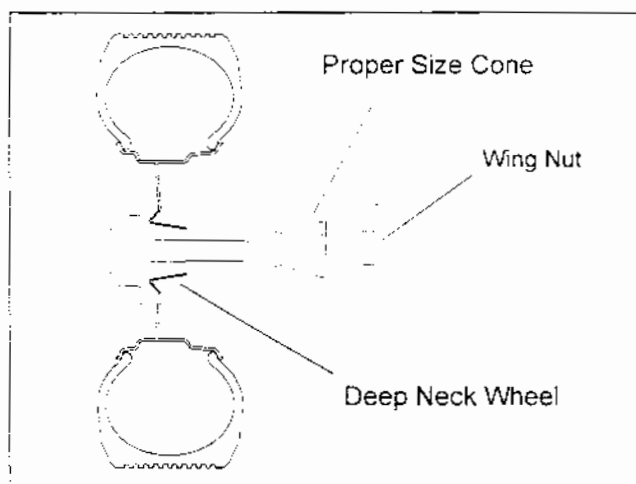

Figure 7 -- Front coning for deep-neck wheels

WARNING!! Failure to tighten wing nut securely may result in serious personal injury.

Truck Wheels

Offset and Ford/Dodge Pinned Dual Wheels Using Optional Offset Spacer

Some light truck wheels are "standard", except that they have offset centers which may extend around the backing plate. Under normal conditions no spacer is required because of the unique design of the balancing shaft and bearing housing. For unusual applications, an optional offset spacer may be used. See the "Optional Accessories for Computer Wheel Balancers" catalog for the part number.

Mount the wheel as shown in *Figure 14* and balance as a "Standard" wheel.

1. Mount offset spacer against the balancer backing plate.
2. Mount wheel onto balancer shaft.
3. Select proper cone and mount onto shaft and into wheel center hole as shown in *Figure 8*.
4. Tighten wing nut securely.

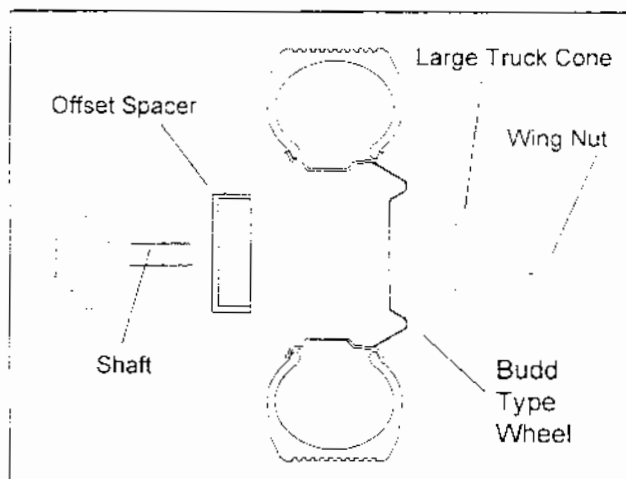

Figure 8 -- Mounting offset wheels

Pinned Wheels

Ford E/F 350 Series and Dodge 350 Series 1-Ton trucks (also some Specialty vehicles, such as motor homes, ambulances, emergency rescue, tow trucks, etc.) may have the safety pinned dual wheels installed on the rear axles.

The Offset Spacer was designed to provide clearance for the pin on these wheels, with a tapered inner lip to allow the clearance needed for the outside mounted cone to fit inside of it without binding. Mount these wheels as in *Figure 8*.

Patch Balance

Some larger light truck tires may require an excessive amount of weight to balance. For this reason a patch balance may be recommended. Patch balancing is simply affixing a stick-on weight designed for the purpose inside the tire body. Wheel/tire weight should be optimized first using a Match Balance procedure. Second perform the actual patch balance procedure. Finally, perform a standard two plane balance. By performing the above procedure the amount of exterior weight placed will be minimum and maximize the tire performance.

Patch Balance Procedure

1. Mount wheel to shaft according to rim design.
2. Measure the overall tire diameter, subtract an estimated amount for tread depth. *Figure 9.*

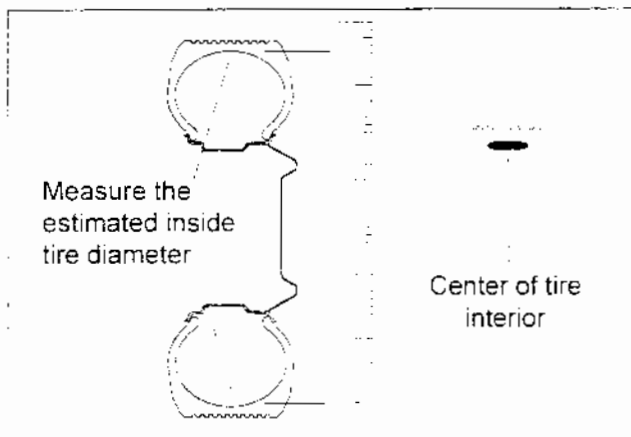

Figure 9 -- Patch balance measurements

3. Enter one half the calculated inside tire diameter amount into the rim diameter window. Enter distance offset and width also.
4. Press the "Lt. Truck Mode" button.
5. Press the static button once to select the outside weight static position.
6. Lower the hood to initiate a spin cycle.
7. Mark the tire at the recommended weight position.
8. Remove the wheel and tire assembly from the balancer.
9. Dismount the tire from the rim, and select a balancing patch one half the displayed weight value. Mount the patch inside the tire center, as instructed by patch manufacturer.
10. Remount the tire to the rim and place the assembly back onto balancer. If a Match Balance was performed, remount the tire according to earlier lineup marks.
11. Perform a standard Lt. Truck dynamic balance.

Lug Mounting - Options

Some wheels may not always locate off the center hole. These wheels use the lugs to center the wheel on the hub. While this is a very accurate method of mounting to a vehicle, it means that if the wheel's center hole is not centered about the lug pattern, then standard cone mounting on a balancer may not give satisfactory balancing results. To accurately balance a lug-centric wheel, an optional lug adapter is necessary. Follow these instructions for proper setup and use of the optional John Bean Unilug Adapter.

1. Count the number of lugs to be used to mount wheel to the vehicle. This number could be 3, 4, 5, 6, 8, or 10 lugs. For 6, 8, 10 lug wheels, the adapter will use every other hole.
2. Select proper hole set ring.
3. Install the set ring and the proper number of arm swivels using supplied shoulder bolts. Do not tighten at this point.
4. Using the hole setting gauge, measure bolt hole circle of the rim.
5. Place the gauge tip onto the swivel arm studs and adjust to the proper bolt circle. Tighten shoulder bolts using the T-handle hex wrench.
6. Mount the adapter plate onto the balancer shaft. Domestic models can be bolted to the face of the backplate. International models can be bolted to the face of the backplate or use the 110570 stub adapter.
7. Mount wheel onto adapter studs and secure with the supplies cone nuts.
8. Enter proper parameters and balance as using appropriate modes.

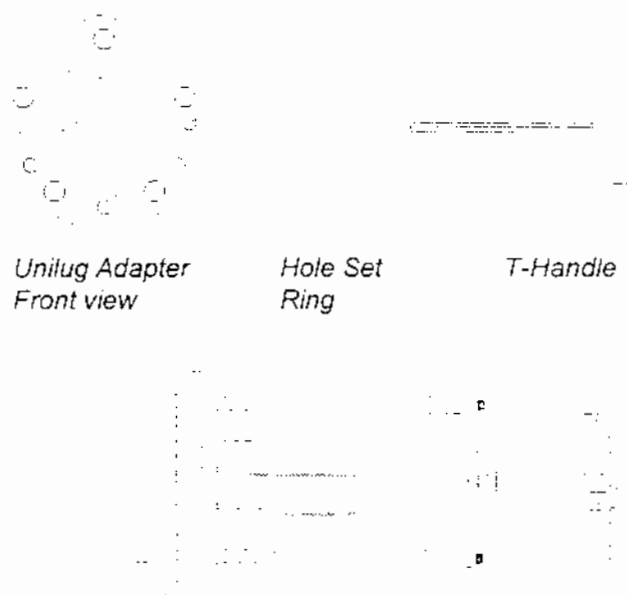

Adapter plate shown mounted to backing collar with stub shaft intact.

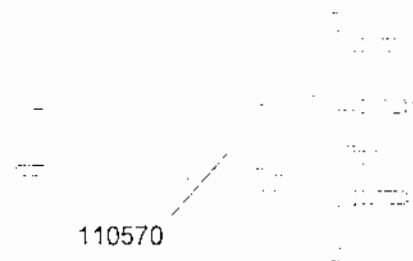

Optional 110570 adapter with Adapter plate. Remove the backing collar assembly prior to use.

Balancing Alloy Wheels

Custom aluminum and alloy wheels mounted on today's high performance autos require a service technician to take several precautions. He must mount the rim in a manner in which no damage will occur, and he must select the proper weight placement location for the particular wheel. Due to the vast diversity of rim designs, it is not feasible to list all possible combinations of rim edges and wheel weight clips. Inspect the rim and available weights and use good judgement in your selection. Weights should not interfere with any suspension parts or make contact during rotation. If a weight does make contact, use tape weights in an alternate location and select an appropriate alloy mode.

WARNING!! Use of improper weight clip attachment could result in personal injury or damage to property. Rim surfaces should be clean and weights should be attached securely.

The John Bean 7 Series Balancers have an Alloy mode keypad for selection of the proper location. See *Figure 10*. Note that the key itself contains a placement representation of the rim and the associated weight location. When an alloy selection is made the weight mode indicator LEDs change accordingly to represent the new location. Press whichever button closely resembles the placement desired and the computer calculates the weight amounts and positions. The Mode keypad allows selection of:

- 5 - Alloy 2 plane positions
- 3 - Static/tape weight positions
- 1 - Standard 2 plane dynamic
- 1 - Match Balance Mode

ALU-S MODE

This is a mode similar to the Alloy mode 1 and 2. The difference is the distance and width parameters are accurately defined by the operator for a more exacting weight placement, therefore improving the likelihood of a single spin balance. Follow the procedures outlined below:

1. Begin by pressing "F18" and ENTER, display should read Alu-ON. If not press "F18" and ENTER again.
2. Select ALLOY 1 or ALLOY 2. The button LED's will blink indicating the ALU-S mode is active.
3. The display reads "d-1" on the left window and the current distance reading is in the right window.
4. Determine the desired location of the tape-on weights. Using the distance gauge, measure the distance to the first (inside) weight location, see *Figure 11*. The value is recorded automatically on the 7.6. Enter the numeric value manually for model 7.5.
5. When the display reads "d-2", repeat step 4 above to enter the distance for the outer weight location plane.
6. Enter the rim diameter. **NOTE: Do Not make an entry for the width value, this has been calculated using the distance values.**
7. Lower the Wheel Guard to begin the spin cycle.

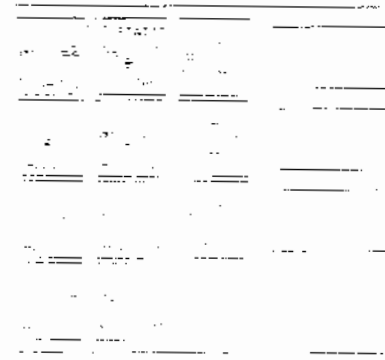

Figure 10 -- Mode Selection Keypad

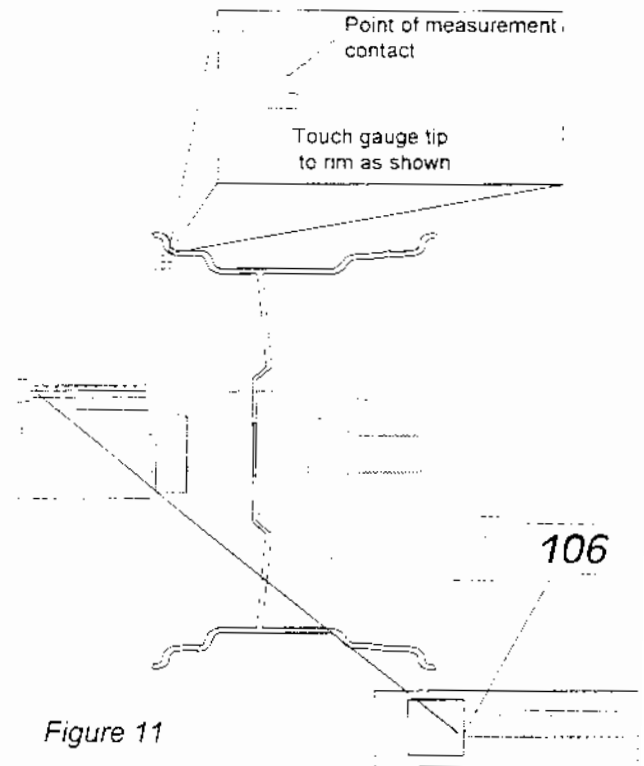

Figure 11

8. Rotate the wheel until the location for the inside weight is indicated.
9. To accurately find the original location of the inside weight on the rim, pull out the distance gauge and observe the numbers changing in the distance parameter window. When the distance number reaches "0", you have located "d1" inner weight position. Place the required weight. Repeat for "d2" for the outer weight. Perform a check spin.

Computerized Match Balance

1. Remove all old balance weights and remove dirt and stones from tire and wheel. Mount the tire wheel assembly on the balancer using the proper mounting method. Enter the proper wheel parameters for DISTANCE, WIDTH & DIAMETER.

2. Press **F 90** & **ENTER** to activate step 1 of the Match Balance procedure. "STP 1" is displayed for approximately 2 seconds.

3. The display then reads "VAL TOP". Rotate the wheel/balancer shaft so the valve stem is at the top (12:00). Mark the tire at top with a chalk line and Press "F".

4. Press **ENTER** or lower the hood for auto-spin to measure the imbalance of Position #1.

5. After the wheel stops, the display shows "ROT 180". Dismount the wheel assembly from the balancer, bring it to a tire changer, break down the beads, and rotate the tire 180 degrees on the wheel. Use the valve stem as a reference when rotating the tire. Inflate the tire to the recommended pressure.

NOTE: If anytime during the procedure, the normal dynamic weight amounts are displayed, install the indicated weight and complete the balance. Calculations are made based on the last selected mode. This is an indication of an insignificant amount of benefit to be gained from the Match Balance procedure. The balancer will cease the match process when these low values are detected. If desired, press F at this time to force completion of the Match Balance.

If a STATIC amount of weight is displayed, this indicates a severe imbalance problem. Examine the mounting method or wheel centering condition for excessive runout. Check the wheel and tire for damage of irregularities. You may force continuation by pressing the "F" key.

6. Install the tire/wheel assembly on the balancer as before.

7. "STP 2" is displayed briefly indicating the balancer is ready to take a second measurement.

8. The display then reads "VAL TOP". Rotate the wheel assembly to position the valve stem at the top center and Press "F".

NOTE: Press STOP to end the Match Balance Procedure at any time.

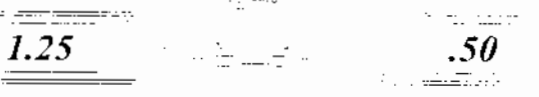
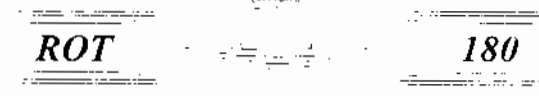
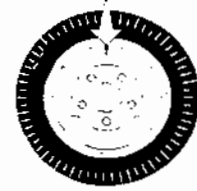
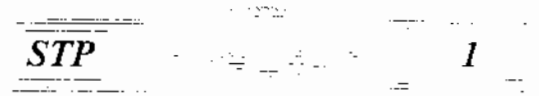

F

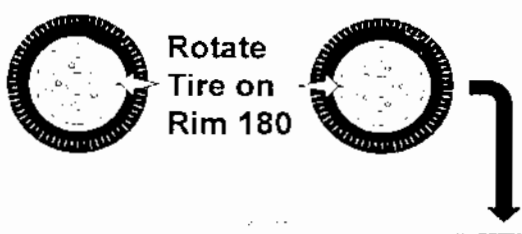

Rotate Tire on Rim 180



Place Tire back on balancer. Place Valve Stem at top and Press "F".



9. Press ENTER or lower the hood for auto-spin to measure the imbalance of Position #2.

10. If "SPOT" is displayed, rotate the wheel balancer shaft until green LED shows on the left position window. Mark the tire at the top center with an "X". This is the tire **Match SPOT**. The wheel's valve stem will be matched to this spot.

If normal dynamic weight amounts are displayed, the Match Balance procedure did not yield any benefit. Install the indicated weight to complete the wheel balance.

If a STATIC amount of weight is displayed, this indicates a severe problem. You may force continuation by pressing "F".

11. **OPTIONAL:** To display the percent of rim (r) or tire (t) problem press "F". This function is useful to diagnose whether the rim or tire has excessive imbalance that may require further analysis. To return to the previous step, press "F" again.

12. In the case where an optimum "SPOT" has been determined, remove the tire/wheel assembly from the balancer and deflate. Break the beads and rotate the **Match SPOT "X"** to align with the valve stem. Inflate the tire to specifications and reinstall the assembly onto the balancer.

13. Press SPIN or lower the hood for auto spin.

14. Place balance weights as indicated to complete the normal balance. This completes the Match Balance procedure.

NOTE: If an error (ER) is displayed, it would indicate an error was made in rotating the tire or an error was made in the procedure. In the case of an error, press STOP and begin the procedure from the start.

SPO

t

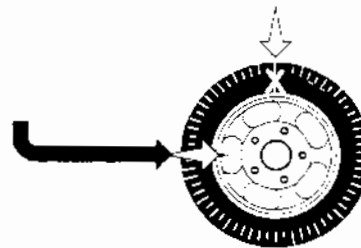

Chalk mark "X" at SPOT

6.25

S

r 30

t 70

Isolate Tire Wheel Problem & display in percent

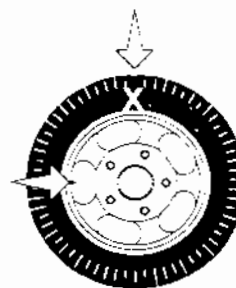

Rotate "X" chalk mark to Valve Stem

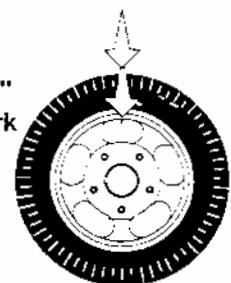

Balance the Tire



0.00

0.00

Multi-Operator Mode

The 7 Series balancers feature an "A/B" selector allowing selection of up to six different operating sessions to be programmed concurrently. This handy feature allows up to six operators to balance independently while the software "remembers" the wheel information and the current balancing mode for each. As the "A/B" button is depressed (Figure 12), the memory toggles through each operator setup. The button LED display will indicate which operator is running. The current operator is also indicated on the weight amount LED window as A, B, C etc. (Figure 13). All operator parameters are stored until the machine is powered down. Each time the balancer is turned on the balancer defaults to the operator "A" mode. The display reads the current operator at the beginning of each spin. The maximum number of operators using the A/B mode key can be set by pressing "F71" and Enter. Press the desired number of operators and enter.

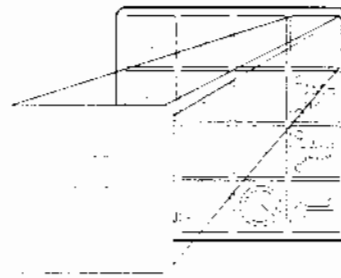

Figure 12 -- Multi-operator selector



Figure 13 -- Operator is indicated each time the A/B button is pressed.

Stored Parameters (F80-83)

This balancer is programmed to allow storage and retrieval of four sets of wheel parameters (Distance, Width and Diameter). This feature is especially useful for a shop that balances a large quantity of one type wheel. It may also be simultaneously used by four individual technicians by storing the parameters for four vehicles. Program the balancer as followings:

1. Assign each of the following "F" codes to a particular wheel/Tire or to an individual technician.
 - F 80 -- Technician #1 or wheel #1
 - F 81 -- Technician #2 or wheel #2
 - F 82 -- Technician #3 or wheel #3
 - F 83 -- Technician #4 or wheel #4
2. Enter the wheel parameters (Distance, Width, and Diameter) in the normal manner.
3. Press the assigned "F" Code, followed by pressing the SPIN button. For example, press F 80 and SPIN.
4. The display will change to the following:
r = 0 S = 1
(recall = 0 Store=1)
5. This instructs the operator to press (1) one on the keypad to "store" the parameters. The parameters are saved until changed by entering and storing new parameters.
6. To recall previous stored parameters, press "0". You will now be in the "recall" mode. Pressing "F" scrolls selection down to the next stored location. Press ENTER to select desired parameters. Press (0) zero on the keypad to RECALL.

Inch and Millimeter

The operator has the option of selecting parameter input to be in inches or millimeters. The selector button displays 2 LEDs which indicate the active mode. When inch mode is selected only parameters in inches can be input. Metric values can only be entered when "MM" is selected.

Ounce and Gram

Ounce or gram can be selected for weight amount readings. Either mode offers equal accuracy. Select the desired mode by pressing the ounce/gram button. An LED displays the mode selected.

"F" / Lt Truck

The **F/Lt Truck** key is used for two functions -- as an activator for programming Functions (F-codes), and as the Light Truck Mode key.

Activate the Light Truck mode by pressing "**F/Lt Truck**" followed by any mode key. The Lt Truck zero weight threshold will be raised to 0.5 ounces. Balance as you would any other wheel. In the light truck mode, the balance mode LEDs will blink. To exit from the truck mode press any mode key by itself.

Calibration of the Wheel Parameter Entry Gauge (F17)

If the balancer has not been calibrated before or whenever the balancer is serviced or relocated, the electronic distance gauge assembly should be calibrated to maximize accuracy. The balancer system features two methods of calibration, the first and most accurate is the three point F17 Parameter gauge calibration. The second is a simpler and faster but not quite as accurate two point calibration, F12. We at John Bean suggest the three point calibration in the interest of maximizing accuracy.

Three Point Calibration - Models 7.6 only

1. Press "F-1-7" and  "ENTER".
2. The display will read "CAL DIS". Rotate the arm a few inches toward the operator position. Move the gauge rod to the rear edge of the backplate, make sure the arm touches the backing plate and the locator ring rests on top of the backing collar. The display will read "CAL PEA" (Parameter Entry Arm) See *Figure 14*.
3. When the display changes to "FLP PEA" flip the distance gauge arm down and touch the locator ring to the bottom of the backing collar. See *Figure 15*. The machine will respond after a couple of seconds then prompt you to return the distance gauge to its normal return position while reading "PEA RTN".
4. When returned the display will then read "SLU PEA". Install the shaft calibration slug into the tapped hole on the outer edge of the backing plate. See *Figure 16*. Rotate the plate and the gauge arm to a point where the arm locator ring touches the end of the weight. After a two second pause in this position, the third dimension is entered automatically.
5. When the display changes to "PEA RTN" again. Return the distance gauge to its normal return position. Gauge calibration is now complete, continue with calibration by performing the "F1" process outlined on *page 20*.

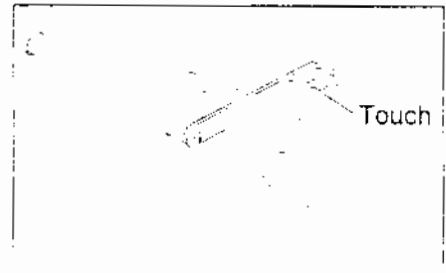

Figure 14

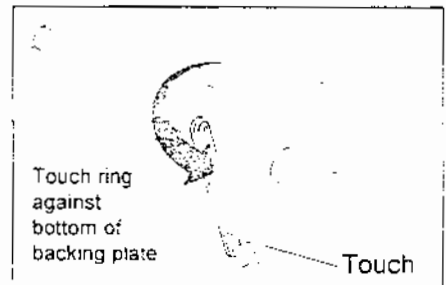

Figure 15

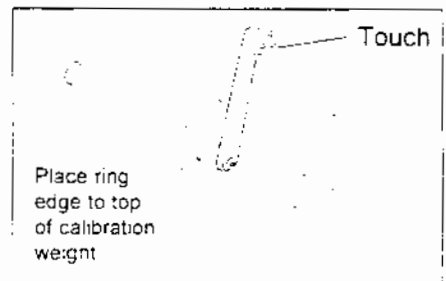

Figure 16

Manual Distance Calibration (F17) - (Model 7.5)

To calibrate, press F17 and *ENTER*. Display reads "CAL DIS". Move the gauge rod toward the backplate, make sure the arm touches the backing plate. Read the value printed on the gauge rod label. Enter this value using the numeric keypad. Press *ENTER*. The calibration distance is now calibrated. See *Figure 17*.

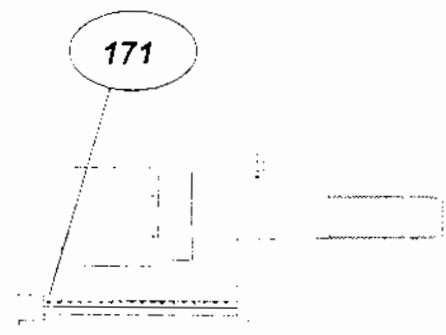



Figure 17

Shaft Calibration of the Balancer

The balancer should be calibrated with scheduled frequency. It is recommended that the balancer be calibrated weekly, if not more often. The programmed calibration monitor will request the operator to calibrate after every 1000 spins. When prompted, the display will read "Cal Due". Operator can choose to temporarily bypass the calibration if desired by pressing "Cancel", the program will then allow you to proceed with operation as normal. In areas that have extreme temperature swings or humidity changes between calibrations, we recommend daily calibration as this will maximize system accuracy under fluctuating environmental conditions. The balancer should also be calibrated whenever service work is performed or whenever the unit has been relocated.

Calibration Procedure

1 - Press F,1 and ENTER  (the Green Key with the arrow).

2 - The display will read "SLU OFF". Remove the calibration weight, if installed and press Enter .

3 - Lower hood or Press ENTER  to initiate the balancer spin cycle.

4 - The display will read "LF PLN". Install the calibration weight in the threaded hole on the inside of the backing plate. *Figure 18.*

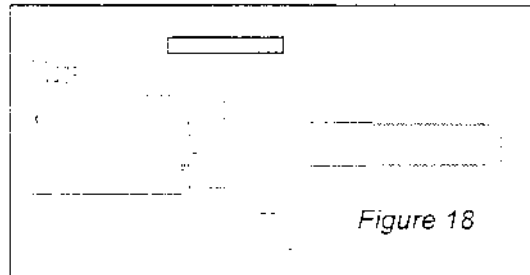



Figure 18

5 - Press ENTER  or lower the hood to initiate the balancer spin cycle. Hood must be lowered to activate spin cycle.

6 - The shaft will brake to a stop. When the display changes to "rt PLN", attach the cylindrical calibration weight in the threaded hole from the outside edge. *Figure 19.*

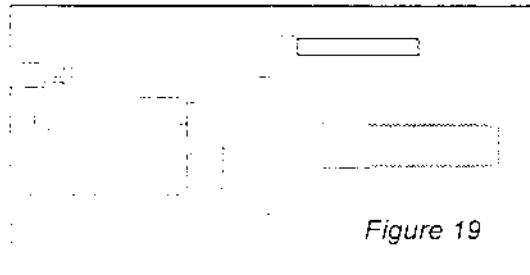



Figure 19

7 - Press ENTER  or lower the hood to initiate the balancer spin cycle. Hood must be lowered to activate spin cycle.

8 - Calibration is then verified by the computer and the display will read "CAL FIN", meaning CALibration is FINished.

If the display reads "shf imb" meaning shaft is imbalanced, or If the display reads "CAL ERR" it is likely that the calibration procedure was not followed correctly. If re-calibration is still unsuccessful contact your John Bean Service Representative for service or technical assistance.

Smart Calibration

The **Smart Calibration** feature will automatically prompt a calibration every 1000 spins. When calibration is due, the balancer will display "CAL DUE". Press "Cancel" to continue operation until next power cycle or press "F1" to calibrate. Check "F72" for the current spin cycle count since last calibration.

Function or "F"-Codes

The 7 Series digital balancer features a set of programmable "F" codes for balancer control, function customizing and troubleshooting. Some "F" codes offer the same control as front panel keys. Below is a listing of these codes. To select a code function press "**F/Lt Truck**" followed by the desired number. Complete by pressing ENTER. 

Calibration

F0 - Recalculation without re-spin. Use this function to compare weights used in various alloy modes.

F1 - Weight measurement calibration, dual plane. This is the standard calibration process used to compensate for mechanical and electric variables. See page 8 for instructions.

F17 - Distance gauge calibration. Any time the balancer is moved or serviced, the distance gauge should be calibrated. See Page 9 for instructions.

F22 - Calibration Quick Check Feature for **7.6 units only**. This code checks the calibration using the precision calibration weight as a reference. When the weight is placed on outside of the backing collar, this code will display "**Cal Fin**" if the calibration is OK.

Display Mode Switching

F2 - Select round-off mode

(.25 ounces/ 5 grams)

F3 - Select non-roundoff mode

(.05 ounces/1 gram)

F4 - Select English display (ounces)

F5 - Select Metric display (grams)

F8 - Fine angle display, switches between 0.35 degrees resolution and 0.7 degrees

F14 - Selects roundoff to .125 mode

OUNCE MODE:

0 - 0.16 will round to 0.00

.161 - .19 will round to 0.13

.191 or greater will round to nearest .125 increment

GRAMS MODE:

0 - 5.0 will round to 0.00

5.001 or greater will round to nearest 1 gram

Operating Mode Switching

F6 - Autospin toggle on and off

F7 - Metric/English diameter toggle

F70 - Displays the Current Operator

F18 - Switches the ALUS modes on and off

Configuration

F15 - Set zero and five gram threshold for rounded ounces and grams

F16 - Resets default threshold for rounded ozs/grams

Panel testing

F30 - Display test - Used for troubleshooting

F31 - Keyboard test - Used for troubleshooting

Analog testing

F42 - Left transducer voltage - Used for troubleshooting

F43 - Right transducer volt - Used for troubleshooting

Digital testing - Machine diagnostic codes

F50 - Displays the encoder position

F51 - Encoder count test - should read 2047

F53 - Displays the shaft speed in rpm - about 370

Mechanical testing

F10 - Noise test (continuous run)

F11 - Displays calibration factors, dual plane mode.

F20 - Display zero shaft unbalance.

Special Functions

F9 - Switches Electronic Weight Location - on/off

F23 - Set the calibration due count to any number less than 1000. Never set to zero, it will always need calibration.

F60 - Displays software program revision number

F71 - Set maximum number of operators using A/B

F80-83 - Auxiliary stored parameters

F90 - Performs a Match Balance

Spin Counters (7.6 models only)

F28 - Displays the user cycle counter. - (Trip meter)

F27 - Clears the user cycle counter

F72 - Total cycles since last calibration, also Displays total spin cycle odometer.

F93 - Clears the optimization counter

Optimization Counter

Count since last calibration

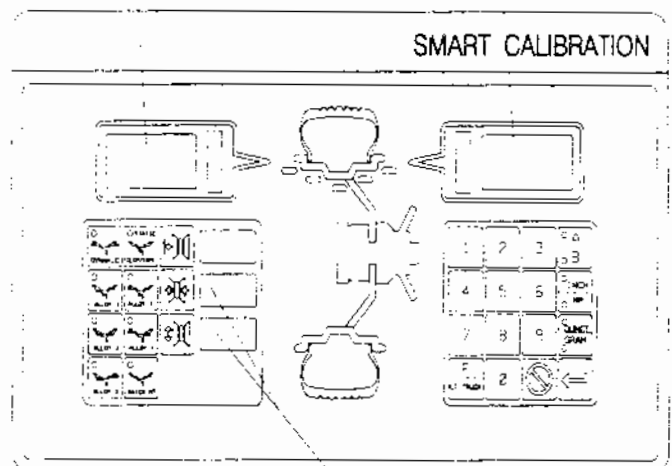

Total spins

Maintenance and Care

The 7 Series balancers require a minimum amount of care. However, minor upkeep will prolong the life of any piece of equipment.

Always maintain the work area in a clean and clear manner. Clutter has the tendency to attract undue dirt and dust. A clean and clear work area is safer.

Periodically clean the display surfaces by wiping with a soft rag. Rag should be sprayed with an evaporating cleaner. Never use a petroleum based cleaner or one which leaves an oily residue. Do not use brake cleaner!

Maintain the weight tray and cone storage area in a clean clear manner. Occasionally clear out old and discarded weights and accumulated dirt/debris. Dispose of lead weights in a proper manner. Do not spray water at and avoid splashing at this machine.

Never allow unauthorized personnel to operate the balancer.

Do not use Non-John Bean recommended accessories and adapters. Tolerances and specifications may not be to designed standards.

Wipe the shaft threads and faceplate occasionally with a bristle brush followed by an oily rag.

Calibrate the balancer in a consistent periodic manner. See page 9-10 for calibration instructions. The balancer will force a calibration every 1000 spins. To view the cycle count press "F, 63 and ENTER".

Troubleshooting

Should you experience some difficulty, follow these procedures.

Operation Problems:

1. Assure proper voltage is supplied to the machine. Do not use extension cords rated for less current than unit demands. See label on unit back panel for draw. Normally cord should be rated for at least 30 amps continuous.
2. Inspect on/off switch - does it have the normal tactile feel?
3. Perform a complete calibration. A calibration will often cure the problem or give a specific error message.

Customer Complaint Problems:

1. Inspect all surfaces of the shaft and shaft adapters. Note any undue wear, deformations, rust or fit.
2. Wheels which have not been mounted according to the rim design may not balance correctly. Try another mounting method, or a different cone and rebalance. Make sure the wing nut is tight. Check for rim slippage on the shaft by marking wheel and shaft.
3. Check for Wheel warpage or runout. Excessive rim or tire runout may require replacement.
4. Inspect the vehicle for worn or loose suspension components which may lend to a rough or undesirable ride.
5. A bad vehicle alignment may create poor ride performance.
6. Make sure your weight placement is correct.
7. Wheel weights should be clean and free of nicks.
8. Use the proper type wheel weight clips. Use of improper weights with a rim design may be hazardous to personal health as well as property.
9. The balancer may need to be mounted to a secure concrete floor surface. There should be no adjacent vibrations which could be transmitted back to the machine. Look for large compressors, hammers, etc.

If difficulty still exists - Before calling for service

Have your balancer model number, serial number, name of business and your telephone number handy.

Many times a problem can be corrected or identified over the telephone. If service is required, an Equi-Serve Technician will be computer dispatched to your business at your request.

For USA Nationwide Equi-Serve Service call:

1-800-362-8326

(1-800-362-8326)

or (501) 450-1500 Fax (501) 450-1585

See the back of this manual for Worldwide John Bean Service and Support locations.

Index

A			O			U		
Accuracy	6		Operation	9		Unpacking	7	
Adjustment of the Display	7		Options	6		V		
Alloy Wheels	15		Ounce and Gram	18		Volume	6	
ALUS mode	15		P			W		
Anchoring	7		Panel Functions	8		Weight	6	
C			Patch Balance	13-14		Wheel Diameter Entry	10, 11	
Calibration	19, 20		Pinned Wheels	13		Wheel Guard	7	
Calipers	6, 10		Placing Weight	12		Wheel Mounting	9, 13	
Calling for service	22		Pockets	6				
Care	22		Power Requirements	6				
Check List	9		Print History	3				
Complaint Problems	22		Q					
Configuration	21		Quick Check	21				
Cycle Time	6		Quick Set Method	10				
D			R					
Dismounting the Wheel	12		Resolution	6				
Distance Entry	10		Rim Diameter	6, 10				
F			Rim Distance	10				
Features	6		Rim Width Entry	10, 11				
Footprint	6, 7		Roundoff	21				
Function or "F"-Codes	21		S					
I			Safety instructions	4				
Inch and Millimeter	18		Shaft Calibration	20				
Installation	7		Shaft Rotation Speed	6				
L			Shaft Size	6				
Lt Truck	18		Site Preparation	7				
Lug Mounting	14		Specialty Wheels	13				
M			Specifications	6				
Maintenance	22		Spin Counters	21				
Manual Distance Calibration	19		Spinning the Wheel	12				
Match Balance	16, 17		Standard Equipment	6				
Max Tire Diameter	6		Storage hooks	7				
Max Tire Weight	6		Stored Parameters	18				
Max Tire Width	6		T					
Mode Selection	10, 11		Table of Content	5				
Motor Rating	6		Three Point Calibration	19				
Motorcycle Adapter	6		Troubleshooting	22				
Mounting Adapter	7		Truck Wheels	13				
Multi-Operator	18							



USA

John Bean Company
309 Exchange Avenue
Conway, Arkansas 72032
Tel.: (800) 362-8326 or (501) 450-1500
Fax: (501) 450-1585

IRELAND

Formguide Services Ltd.
T/a John Bean Company
Sitecast Industrial Estate
Little Island, Cork
Tel: (353) 21-354477
Fax: (353) 21-354488

GERMANY

John Bean Auto Service Gerate
Division to Sun Electric Deutschland GmbH
Gewerbepark Sinn
D-35764 Sinn Herborner Str. 7-9
Tel: (49) 2772-9404-0
Fax: (49) 2772-94042-23

FRANCE

John Bean Company
Z.I. Du Haut Galy - Galy 8
93623 Aulnay S/S Bois
Tel: (33) 1-4865-3828
Fax: (33) 1-4865-7331

CANADA

John Bean Company
6500 Millcreek Drive
Mississauga, Ontario
Canada L5N 2W6
Tel: (905) 814-0114
Fax: (905) 814-0110

LATIN AMERICA

Rua Apinages
1268 cj. 605B
Perdizes-Sao Paulo-S.P.
Cep: 05017-0000
Brazil
Tel: (55) 11-871-0713
Fax: (55) 11-871-0713

Notice: The information contained in this document is subject to change without notice. **John Bean Company** makes no warranty with regard to this material. **John Bean Company** shall not be liable for errors contained herein or for incidental consequential damages in connection with furnishings, performance, or use of this material.

This document contains proprietary information which is protected by copyright and patents. All rights are reserved. No part of this document may be photocopied, reproduced, or translated without prior written consent of **John Bean Company**.

 is a registered trademark of the John Bean Company and Snap-on Incorporated