

CHAPTER 5 PARTS

PARTS BY PICTORIAL

This chapter describes assemblies / subassemblies / parts considered replaceable at on-site field installation.

NOTE: The following is a breakdown description of the Serial Number

Serial # Location –Bottom of unit

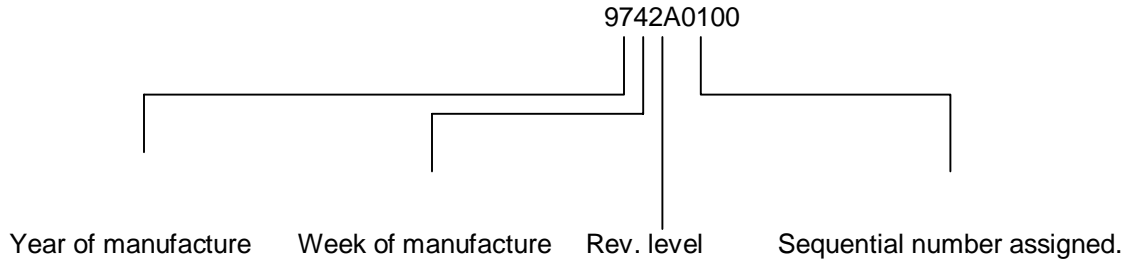

FRONT VIEW

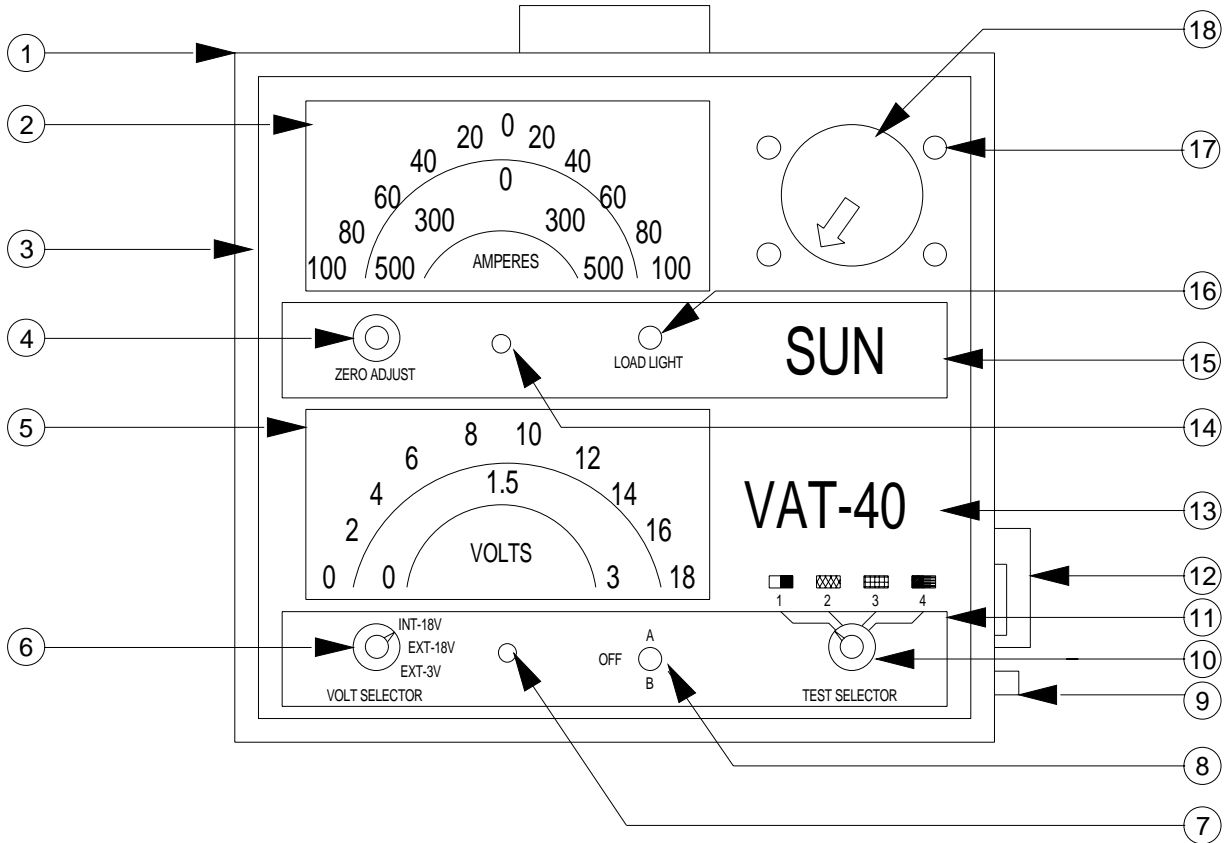

ITEM	DESCRIPTION	PART NUMBER	ITEM	DESCRIPTION	PART NUMBER
1a	Case Assembly (Blue)	7009-1054	11	Overlay, Lower Panel	4055-0155
1b	Case Assembly (Silver)	7009-1054-03	12	Connector, Panel (J3)	4161-0805
a	Screw #10-32x3/8 (4)	0410-0016	a	Terminal, Contact (5)	4162-0927
b	Panel, Rear	7020-1390	b	O-Ring	4162-0938
c	Bolt #8x3/8 (2)	0601-0044	c	Washer, Slip Joint	0400-0625
2	Meter, Amp (M1)	0746-0146	d	Connector, Clamp	0795-0328
a	Meter, Cover	0941-0086-01	e	Bushing, Insulator	0795-0343
b	Meter, Amp Face Plate	0880-0811	13a	Panel, Control (Blue)	7020-1407
3	Molding, Trim	0642-0502-02	13b	Panel, Control (Silver)	7020-1886
4a	Zero Adjust Control	0685-0334	14	Button, Meter Zero	0940-0143
4b	Knob, Zero Adjust	0758-0158	15	Overlay, Upper Panel	4055-0154
5	Meter, Volt (M2)	0746-0147	16a	Light, Load Indicator	0709-0111
a	Meter, Cover	0941-0086-01	16b	Fast-Ons	0676-0072
b	Meter, Volt Face Plate	0880-0810	17	Nut, Cap	0407-0006
6a	Switch, Volt Selector	0762-0201	18a	Knob, Carbon Pile	7009-1457
6b	Knob, Volt Selector	0758-0158	18b	Screw, Lead (Pile)	0784-0001
7	Button, Meter Zero	0940-0143			
8	Switch, Field Selector	0689-0097			
9	Bushing, Heyco (3)	2300-0000			
10a	Knob, Test Selector	0758-0158	NS	Wiring Harness Complete	7076-0200
10b	Switch, Test Selector	0762-0214	NS	Circuit Board	7009-1112

STAND (PTS-40)

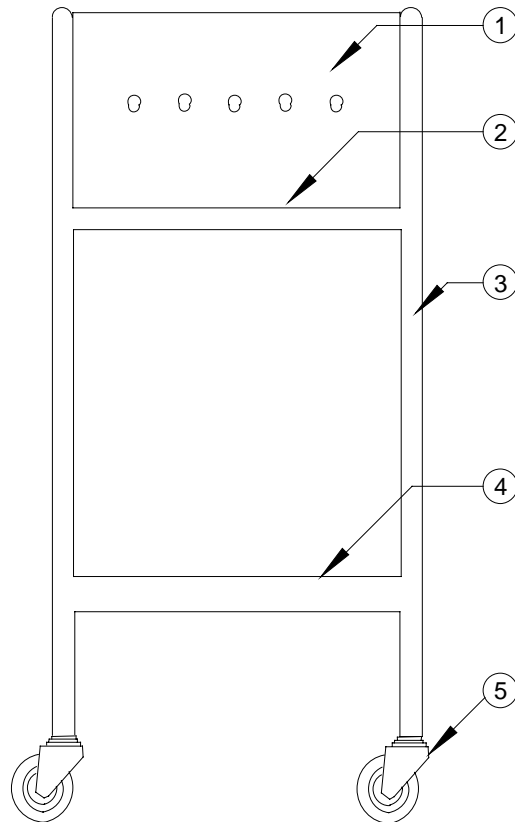

ITEM	DESCRIPTION	PART NUMBER	ITEM	DESCRIPTION	PART NUMBER
1	Plate, Unit Mount	7003-0423-01	4a	Shelf	7022-0023-01
2a	Shelf	7022-0023-01	4b	Mat, Shelf	7019-0031
2b	Mat, Large Shelf	7019-0035	5a	3" Caster	3645-0039
2c	Mat, Small Shelf	7019-0034	5b	Caster Socket	3645-0508
3	Legs, Chrome Plated	7015-0021			

CARBON PILE ASSEMBLY (7036-0029)

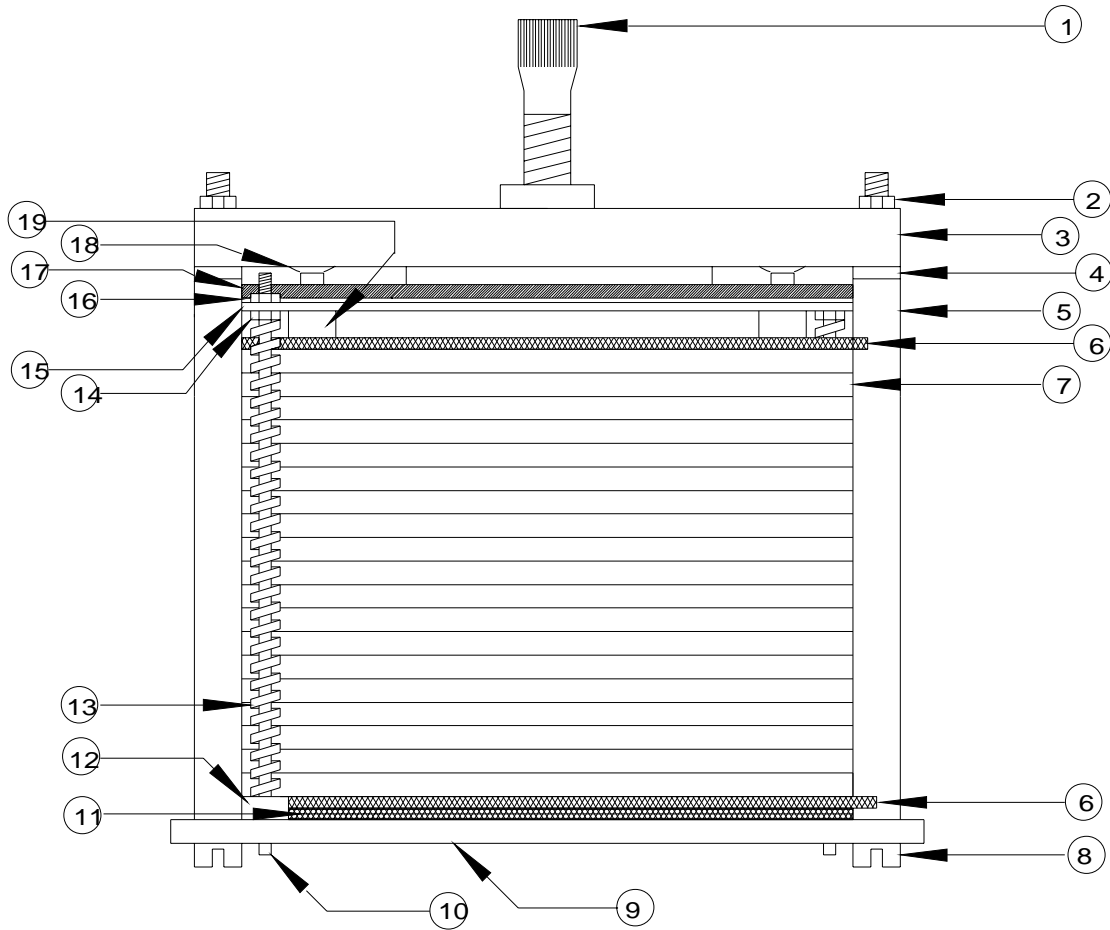

ITEM	DESCRIPTION	PART NUMBER	ITEM	DESCRIPTION	PART NUMBER
1a	Screw, Lead	0784-0001	10	Guide Rod	1663-0003
2	Nut #10-24	0409-0083	11	Insulator	0261-0004
3	Bushing Plate Assy.	1956-0011	12	Porcelain Insulator	0268
4	Flat Washer #10	0400-0022	13	Return Spring	0267-0003
5a	Porcelain Insulator	0258-0004	14	Nut #5-40	0409-0006
5b	Spacer Sleeve	0401-0363	15	Contact Plate, Upper	0255-0011
6	Brass Plate	2092-0001	16	Insulator	0261-0003
7	Carbon Plate	0262-0001	17	Pressure Plate	0254-0001
8	Screw #10-24x4-1/8	0410-0123	18	Spring Washer	0699-0010
9	Anchor Plate	2091-0001	19	Porcelain Insulator	0258-0002

CABLE ACCESSORIES

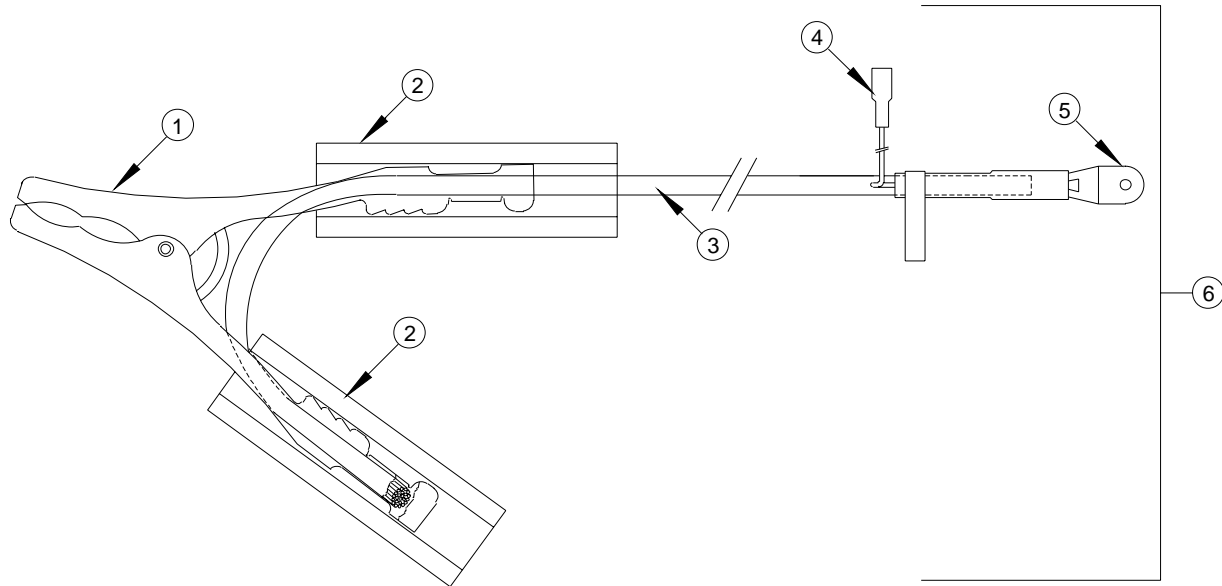

ITEM	DESCRIPTION	PART NUMBER	ITEM	DESCRIPTION	PART NUMBER
1	Clip, Battery	4345-0010	4	Terminal (Male)	0676-0124
2a	Insulator, Red	4345-0013	5	Terminal (Lug)	0676-0651
2b	Insulator, Black	4345-0014	6a	Cable, Red Battery	6002-0339-01
3	Cable, 90" Battery	0663-0307	6b	Cable, Black Battery	6002-0339-02

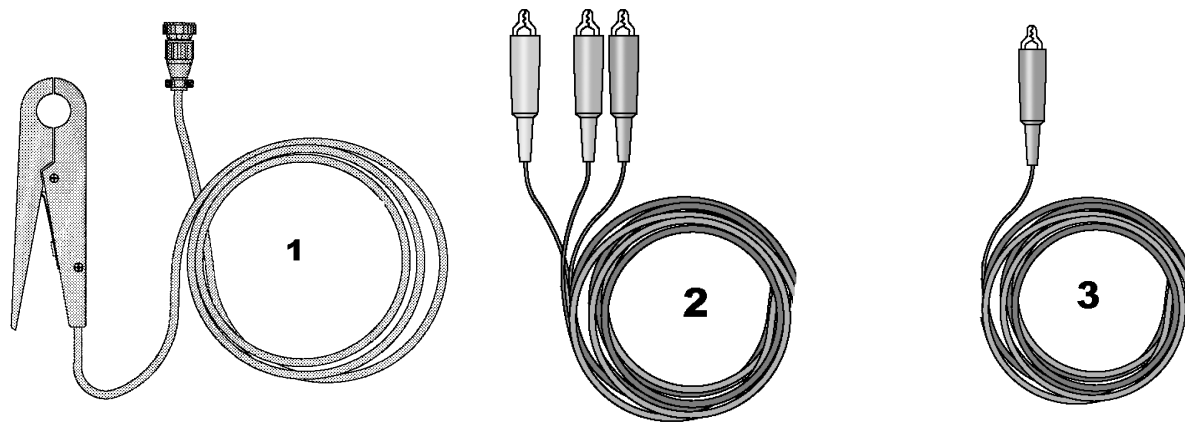

ITEM	DESCRIPTION	PART NUMBER	ITEM	DESCRIPTION	PART NUMBER
1	Cable, Amp Probe	6005-0133	2a	Cable, Blue Field	6002-0301
1a	Spring Clip	0711-0224	2b	Clip	0672-0003
2a	Cable, Red Ext. Volts	6002-0300	2c	Insulator, Blue	0809-0001
2b	Cable, Black Ext. Volts	6002-0299			
2c	Clip	0672-0003			
2d	Insulator, Red	0190-0002			
2e	Insulator, Black	0190-0001	NS	Battery Probe Adapter	7010-0218

PARTS IN ALPHABETICAL ORDER

DESCRIPTION	PART NUMBER	COMMENTS
Anchor Plate	2091-0001	For Carbon Pile
Battery Probe Adapter	7010-0218	Optional
Board, Circuit	7009-1112	
Bolt #8x3/8	0601-0044	2 Qty.
Brass Plate	2092-0001	For Carbon Pile
Bushing Plate Assy.	1956-0011	For Carbon Pile
Bushing, Heyco (3)	2300-0000	
Bushing, Insulator	0795-0343	
Button, Meter Zero	0940-0143	
Button, Meter Zero	0940-0143	
Cable, 90" Battery	0663-0307	For Battery Load Leads
Cable, Amp Probe	6005-0133	
Cable, Black	6002-0299	Ext. Volts
Cable, Black Battery	6002-0339-02	For Battery Load Leads
Cable, Blue	6002-0301	Field
Cable, Red	6002-0300	Ext. Volts
Cable, Red Battery	6002-0339-01	For Battery Load Leads
Carbon Plate	0262-0001	For Carbon Pile
Case Assembly	7009-1054	Blue
Case Assembly	7009-1054-03	Silver
Caster	3645-0039	3"
Caster Socket	3645-0508	
Clip	0672-0003	For Volt and Field Leads
Clip, Battery	4345-0010	For Battery Load Leads
Connector, Clamp	0795-0328	
Connector, Panel	4161-0805	J3
Contact Plate, Upper	0255-0011	For Carbon Pile
Fast-Ons	0676-0072	
Flat Washer #10	0400-0022	For Carbon Pile
Guide Rod	1663-0003	For Carbon Pile
Insulator	0261-0003	For Carbon Pile
Insulator	0261-0004	For Carbon Pile
Insulator, Black	0190-0001	For Volt Lead
Insulator, Black	4345-0014	For Battery Load Leads
Insulator, Blue	0809-0001	For Field Lead
Insulator, Red	0190-0002	For Volt Lead
Insulator, Red	4345-0013	For Battery Load Leads
Knob, Carbon Pile	7009-1457	
Knob, Test Selector	0758-0158	
Knob, Volt Selector	0758-0158	
Knob, Zero Adjust	0758-0158	
Legs, Chrome Plated	7015-0021	
Light, Load Indicator	0709-0111	
Mat, Large Shelf	7019-0035	
Mat, Shelf	7019-0031	
Mat, Small Shelf	7019-0034	
Meter	0746-0146	Amp (M1)
Meter	0746-0147	Volt (M2)
Meter	0941-0086-01	Cover
Meter, Face Plate	0880-0810	Volt
Meter, Face Plate	0880-0811	Amp
Molding, Trim	0642-0502-02	
Nut #10-24	0409-0083	For Carbon Pile
Nut #5-40	0409-0006	For Carbon Pile

DESCRIPTION	PART NUMBER	COMMENTS
Nut, Cap	0407-0006	
O-Ring	4162-0938	
Overlay, Lower Panel	4055-0155	
Overlay, Upper Panel	4055-0154	
Panel, Control	7020-1407	Blue
Panel, Control	7020-1886	Silver
Panel, Rear	7020-1390	
Plate, Unit Mount	7003-0423-01	
Porcelain Insulator	0258-0002	For Carbon Pile
Porcelain Insulator	0258-0004	For Carbon Pile
Porcelain Insulator	0268	For Carbon Pile
Pressure Plate	0254-0001	For Carbon Pile
Return Spring	0267-0003	For Carbon Pile
Screw #10-24x4-1/8	0410-0123	For Carbon Pile
Screw #10-32x3/8	0410-0016	4 Qty.
Screw, Lead	0784-0001	For Carbon Pile
Shelf	7022-0023-01	
Shelf	7022-0023-01	
Spacer Sleeve	0401-0363	For Carbon Pile
Spring Clip	0711-0224	For Amp Probe
Spring Washer	0699-0010	For Carbon Pile
Switch, Field Selector	0689-0097	
Switch, Test Selector	0762-0214	
Switch, Volt Selector	0762-0201	
Terminal (Lug)	0676-0651	For Battery Load Leads
Terminal (Male)	0676-0124	For Battery Load Leads
Terminal, Contact	4162-0927	5 Qty
Washer, Slip Joint	0400-0625	
Wiring Harness Complete	7076-0200	Easy Replacement
Zero Adjust Control	0685-0334	

PARTS IN NUMERIC ORDER

PART NUMBER	DESCRIPTION	COMMENTS
0190-0001	Insulator, Black	For Volt Lead
0190-0002	Insulator, Red	For Volt Lead
0254-0001	Pressure Plate	For Carbon Pile
0255-0011	Contact Plate, Upper	For Carbon Pile
0258-0002	Porcelain Insulator	For Carbon Pile
0258-0004	Porcelain Insulator	For Carbon Pile
0261-0003	Insulator	For Carbon Pile
0261-0004	Insulator	For Carbon Pile
0262-0001	Carbon Plate	For Carbon Pile
0267-0003	Return Spring	For Carbon Pile
0268	Porcelain Insulator	For Carbon Pile
0400-0022	Flat Washer #10	For Carbon Pile
0400-0625	Washer, Slip Joint	
0401-0363	Spacer Sleeve	For Carbon Pile
0407-0006	Nut, Cap	
0409-0006	Nut #5-40	For Carbon Pile
0409-0083	Nut #10-24	For Carbon Pile
0410-0016	Screw #10-32x3/8	4 Qty.
0410-0123	Screw #10-24x4-1/8	For Carbon Pile
0601-0044	Bolt #8x3/8	2 Qty.
0642-0502-02	Molding, Trim	
0663-0307	Cable, 90" Battery	For Battery Load Leads
0672-0003	Clip	For Volt and Field Leads
0676-0072	Fast-Ons	
0676-0124	Terminal (Male)	For Battery Load Leads
0676-0651	Terminal (Lug)	For Battery Load Leads
0685-0334	Zero Adjust Control	
0689-0097	Switch, Field Selector	
0699-0010	Spring Washer	For Carbon Pile
0709-0111	Light, Load Indicator	
0711-0224	Spring Clip	For Amp Probe
0746-0146	Meter	Amp (M1)
0746-0147	Meter	Volt (M2)
0758-0158	Knob, Test Selector	
0758-0158	Knob, Volt Selector	
0758-0158	Knob, Zero Adjust	
0762-0201	Switch, Volt Selector	
0762-0214	Switch, Test Selector	
0784-0001	Screw, Lead	For Carbon Pile
0795-0328	Connector, Clamp	
0795-0343	Bushing, Insulator	
0809-0001	Insulator, Blue	For Field Lead
0880-0810	Meter, Face Plate	Volt
0880-0811	Meter, Face Plate	Amp
0940-0143	Button, Meter Zero	
0940-0143	Button, Meter Zero	
0941-0086-01	Meter	Cover
1663-0003	Guide Rod	For Carbon Pile
1956-0011	Bushing Plate Assy.	For Carbon Pile
2091-0001	Anchor Plate	For Carbon Pile
2092-0001	Brass Plate	For Carbon Pile
2300-0000	Bushing, Heyco (3)	
3645-0039	Caster	3"
3645-0508	Caster Socket	

CHAPTER 5 PARTS

PART NUMBER	DESCRIPTION	COMMENTS
4055-0154	Overlay, Upper Panel	
4055-0155	Overlay, Lower Panel	
4161-0805	Connector, Panel	J3
4162-0927	Terminal, Contact	5 Qty
4162-0938	O-Ring	
4345-0010	Clip, Battery	For Battery Load Leads
4345-0013	Insulator, Red	For Battery Load Leads
4345-0014	Insulator, Black	For Battery Load Leads
6002-0299	Cable, Black	Ext. Volts
6002-0300	Cable, Red	Ext. Volts
6002-0301	Cable, Blue	Field
6002-0339-01	Cable, Red Battery	For Battery Load Leads
6002-0339-02	Cable, Black Battery	For Battery Load Leads
6005-0133	Cable, Amp Probe	
7003-0423-01	Plate, Unit Mount	
7009-1054	Case Assembly	Blue
7009-1054-03	Case Assembly	Silver
7009-1112	Board, Circuit	
7009-1457	Knob, Carbon Pile	
7010-0218	Battery Probe Adapter	Optional
7015-0021	Legs, Chrome Plated	
7019-0031	Mat, Shelf	
7019-0034	Mat, Small Shelf	
7019-0035	Mat, Large Shelf	
7020-1390	Panel, Rear	
7020-1407	Panel, Control	Blue
7020-1886	Panel, Control	Silver
7022-0023-01	Shelf	
7022-0023-01	Shelf	
7076-0200	Wiring Harness Complete	Easy Replacement